

Agilent Technologies Z5623A Option H83

User's and Service Guide

Use this manual with the following documents:

PNA Series Network Analyzer On-line Help System

Application Note 1408-12



Agilent Technologies

Manufacturing Part Number: Z5623-90070

Printed Date: February 2008

Supersede: March 2007

© Copyright 2004, 2006- 2008 Agilent Technologies, Inc. All rights reserved.

Warranty Statement

THE MATERIAL CONTAINED IN THIS DOCUMENT IS PROVIDED “AS IS,” AND IS SUBJECT TO BEING CHANGED, WITHOUT NOTICE, IN FUTURE EDITIONS. FURTHER, TO THE MAXIMUM EXTENT PERMITTED BY APPLICABLE LAW, AGILENT DISCLAIMS ALL WARRANTIES, EITHER EXPRESS OR IMPLIED WITH REGARD TO THIS MANUAL AND ANY INFORMATION CONTAINED HEREIN, INCLUDING BUT NOT LIMITED TO THE IMPLIED WARRANTIES OF MERCHANTABILITY AND FITNESS FOR A PARTICULAR PURPOSE. AGILENT SHALL NOT BE LIABLE FOR ERRORS OR FOR INCIDENTAL OR CONSEQUENTIAL DAMAGES IN CONNECTION WITH THE FURNISHING, USE, OR PERFORMANCE OF THIS DOCUMENT OR ANY INFORMATION CONTAINED HEREIN. SHOULD AGILENT AND THE USER HAVE A SEPARATE WRITTEN AGREEMENT WITH WARRANTY TERMS COVERING THE MATERIAL IN THIS DOCUMENT THAT CONFLICT WITH THESE TERMS, THE WARRANTY TERMS IN THE SEPARATE AGREEMENT WILL CONTROL.

DFARS/Restricted Rights Notice

If software is for use in the performance of a U.S. Government prime contract or subcontract, Software is delivered and licensed as “Commercial computer software” as defined in DFAR 252.227-7014 (June 1995), or as a “commercial item” as defined in FAR 2.101(a) or as “Restricted computer software” as defined in FAR 52.227-19 (June 1987) or any equivalent agency regulation or contract clause. Use, duplication or disclosure of Software is subject to Agilent Technologies’ standard commercial license terms, and non-DOD Departments and Agencies of the U.S. Government will receive no greater than Restricted Rights as defined in FAR 52.227-19(c)(1-2) (June 1987). U.S. Government users will receive no greater than Limited Rights as defined in FAR 52.227-14 (June 1987) or DFAR 252.227-7015 (b)(2) (November 1995), as applicable in any technical data.

Safety Notes

The following safety notes are used throughout this document. Familiarize yourself with each of these notes and its meaning before performing any of the procedures in this document.

WARNING	Warning denotes a hazard. It calls attention to a procedure which, if not correctly performed or adhered to, could result in injury or loss of life. Do not proceed beyond a warning note until the indicated conditions are fully understood and met.
----------------	---

CAUTION	Caution denotes a hazard. It calls attention to a procedure that, if not correctly performed or adhered to, could result in damage to or destruction of the instrument. Do not proceed beyond a caution sign until the indicated conditions are fully understood and met.
----------------	---

Definitions

- Specifications describe the performance of parameters covered by the product warranty (temperature – 0 to 55 °C, unless otherwise noted.)
- *Typical* describes additional product performance information that is not covered by the product warranty. It is performance beyond specification that 80% of the units exhibit with a 95% confidence level over the temperature range 20 to 30 °C. Typical performance does not include measurement uncertainty.
- *Nominal* values indicate expected performance, or describe product performance that is useful in the application of the product, but is not covered by the product warranty.

Contents

Z5623A Option H83

Description	2
Verifying the Shipment	3
General Information	4
Video Feedthru	5
Electrical Preparations	6
Environmental Preparations	8
Electrostatic Discharge Protection	9
Test Set Familiarization	10
Front Panel	10
Power On Switch	10
Power LED	10
RF Connectors	10
Pulse Connector	10
Rear Panel	11
Line Module	11
Power Cables	11
The Line Fuse	12
Operation	13
System Setup	16
Pulse Test Set Control Program	20
Getting Started	20
Pulse Control Program Installation	21
Accessing the Program	24
Control Panel Features	26
Controlling the Test Set	27
Commands	27
Typeface Key Conventions	27
PNA Control	28
Addressing Directly	30
RMB	30
VEE	31
Quick Basic	33
National Instruments VISA	34
Parallel Port	34
Direct Control	36
Controlling the Switches	36
Switch Indicators	36
Switch Indicator Function	38
Controlling the Attenuators	39
Making High Power Measurements With Option H83	42
Initial Setup	42
Determining Power Levels	44
Selecting Power Ranges and Attenuator Settings	46
Additional Setup	48
Final Setup and Response Calibration	49

Contents

Test Set Internal Configurations	51
Bypass	51
High Power	52
Pulse	52
Pulse High Power	53
Amplifier Terminate	53
Specification	54
Pulsed RF PIN Switch Modulator	54
E8362B Option H11	54
Test Set Performance Verification	55
Equipment Required	55
Procedure	56
CPLR Thru S-Parameters	57
RCVR Port S-Parameters	58
On/Off Switch Ratio	59
Attenuator Settings	60
Rear Panel Termination Test	61
Rise and Fall Time Test	62
Replaceable Parts	67

Safety and Regulatory Information

Introduction	70
Connector Care and Cleaning	70
Before Applying Power	70
Shipping Instructions	70
Declaration of Conformity	70
Statement of Compliance	70
Compliance with Canadian EMC Requirements	71
Compliance with German Noise Requirements	71
Warnings	72
Cautions	73
Instrument Markings	74
Contacting Agilent Sales and Service Offices	75

Z5623A Option H83

Description

The Agilent Z5623AH83 is a 2 GHz to 20 GHz dual directional pulse test set. When connected to the E8362B Series Network Analyzer with Option H08 (Pulse) and H11 (IF access) allows pulse measurements to be made from 2 GHz to 20 GHz for both the forward and reverse parameters. The Z5623AH83 can be configured in many ways. The Bypass configuration allows the E8362B Series Network Analyzer to be used from 10 MHz to 20 GHz depending on the analyzer. This mode bypasses the test sets internal 2 GHz to 20 GHz PIN modulator switch. In the Pulse mode the user can configure the test set for their application needs, such as straight un-condition pulse measurements or permit the insertion of high power amplifiers and other signal conditioning equipment. This allows high power measurements at RF levels up to 20 Watts (+43 dBm) from 10 MHz to 20 GHz. This document details a step by step procedure to configure the test set for high power operation.

Control of the Agilent Z5623AH83 Dual Directional Pulse Test Set can be performed either by GPIB or directly. Both methods control the Port 1 and 2 internal switches and attenuators. Direct control requires the user to connect to two 37-pin D-Sub connectors that are located on the rear panel. Both GPIB and direct control cannot be used simultaneously. When used in the direct control mode the test sets front panel LCD indicator may differ from the user setup.

High power configurations require that attenuators and isolators be connected to the test ports and receivers to protect the E8362B. The Agilent E8362BH85 High Power Configurable PNA Series Network Analyzer when ordered with the Option H08 and H11 can be used for high power pulse measurement applications. More information on the setup and configuration can be found in the E8362B, E8363B and E8364B Option H85 User's and Service Guide Supplement (E8364-90027).

Information regarding the PNA Option H08 and H11 can be found in the PNA online help system.

The instrument is shipped from the factory with jumper cables installed on the front panel in what is called the Shipped Configuration. Refer to [Figure 11 on page 15](#).

Two high pass filters (Z5623-80027) have been provided with the Test Set. These filters are used externally to eliminate video feed through from the PIN switch. The filters are used for measurements in the range of 2 GHz to 20 GHz.

The pulse test set can be used from 400 MHz to 2 GHz but is not specified. No band pass filters are provided for this frequency range. If low frequency pulse measurements are required the user must supply the necessary high pass filter.

Verifying the Shipment

After the test set has been unpacked, keep the original packaging materials so they can be used if you need to transport the instrument.

Check the items received against [Table 1](#) to make sure you have received everything.

Inspect the test set and all accessories for any signs of damage that may have occurred during shipment. If your test set or any accessories appear to be damaged or missing, refer to [“Contacting Agilent Sales and Service Offices” on page 75](#).

Table 1 **Content List**

Agilent Part Number	Description	Qty
00909-60006	3.5 mm Male Termination	4
1250-0774	BNC short	2
1250-1788	Adapter sma(m) to sma(m)	2
5062-6681	Cable sma – 6 inches	2
5063-9226	Kit — Front Handles	1
5063-9232	Kit — Rack Mount	1
5064-3851	RCVR Jumper (rack mount)	2
5064-3852	Source Jumper (rack mount)	2
5064-3853	CPLR THRU Jumper (rack mount)	2
5064-3856	RCVR Jumper (bench mount)	2
5064-3857	Source Jumper (bench mount)	2
5064-3858	CPLR THRU Jumper (bench mount)	2
08720-20098	Front Panel Jumper (installed)	6
Z5623-10014	Pulse Test Set Control Programs disk	1
Z5623-80027	μ -Wave High Pass Filter 2 - 20 GHz	2
Z5623-60202	37-Pin D-SUB Jumper	2
Z5623-90070	User’s and Service Guide	1
Power Cord	See Figure 4 on page 7	1

General Information

Environmental:

Operating Temperature Range	0 to 55 °C
Non-Operating Temperature Range	-40 to 70 °C
Operating Humidity Range	Maximum relative humidity 80% for temperatures up to 31 °C decreasing linearly to 50% relative humidity at 40 °C (unless specified otherwise).
Non-Operating Humidity Range	Maximum relative humidity 90% for temperatures up to 65 °C (noncondensing).
Operating Altitude	4572 meters (15,000 ft)
Non-Operating Altitude	15,240 meters (50,000 ft)
EMC	Meets the conducted and radiated interference and immunity requirements of IEC/EN 61326-1. Meets radiated emission requirements of CISPR Pub 11/1997 Group 1 Class A.
Indoor/Outdoor Use	Indoor Use (unless specified otherwise) This product is designed for use in INSTALLATION CATEGORY II and POLLUTION DEGREE 2, per IEC 61010-1 Second Edition and 664 respectively.

Power Requirements:

Frequency	50 to 60 Hz
Voltage	100/115/230/240VAC
Power	40 Watts

Weights and Dimensions:

Net Weight	9.1 kg (20 lb.)
Dimensions	Height: 9 cm (3.54 in) Width: 42.5 cm (16.7 in) Depth: 50 cm (19.7 in)

Video Feedthru

Video leakage refers to the spurious signals present at the RF ports of the switch when it is switched without an RF signal present. Refer to [Figure 1](#). These signals arise from the waveforms generated by the switch driver and, in particular, from the leading edge voltage spike required for high speed switching of PIN diodes. When measured into a 50 Ω system, the magnitude of the video leakage can be as much as several volts. The frequency content is concentrated in the band below 250 MHz, although measurable levels can be observed as high as several GHz. The magnitude of the video leakage can be reduced significantly by adding a high pass filter in the RF path Pulse Out to Filter In. Refer to [Figure 2](#). The picture below shows the leading and trailing edges of video feedthru.

Figure 1 Video Filter

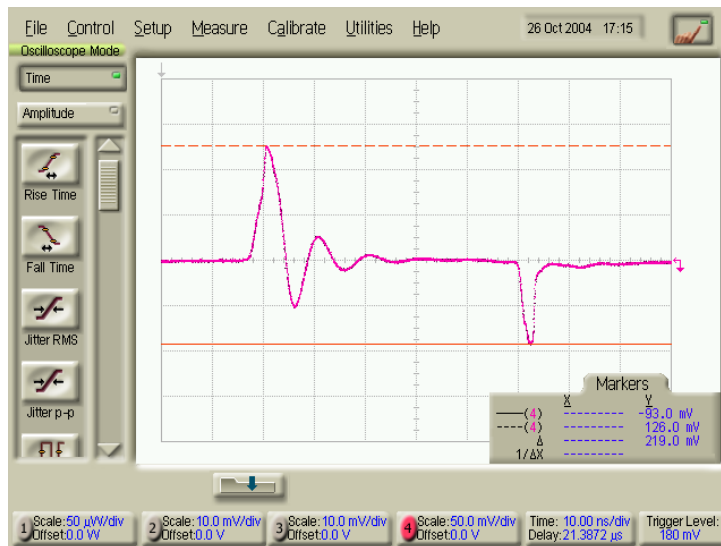

Figure 2 Video Filter and Parts



Electrical Preparations

1. Ensure that the “[Power Requirements:](#)” on page 4 are met.
2. Verify that the power cable is not damaged and that the power source outlet provides a protective earth ground contact. Note that [Figure 3](#) depicts only one type of power source outlet. Refer to [Figure 4](#) to see the different types of power cord plugs that can be used with your test set.

Cables are available in different lengths. For descriptions and part numbers of cables other than those described in [Figure 4](#), Refer to “[Contacting Agilent Sales and Service Offices](#)” on page 75.





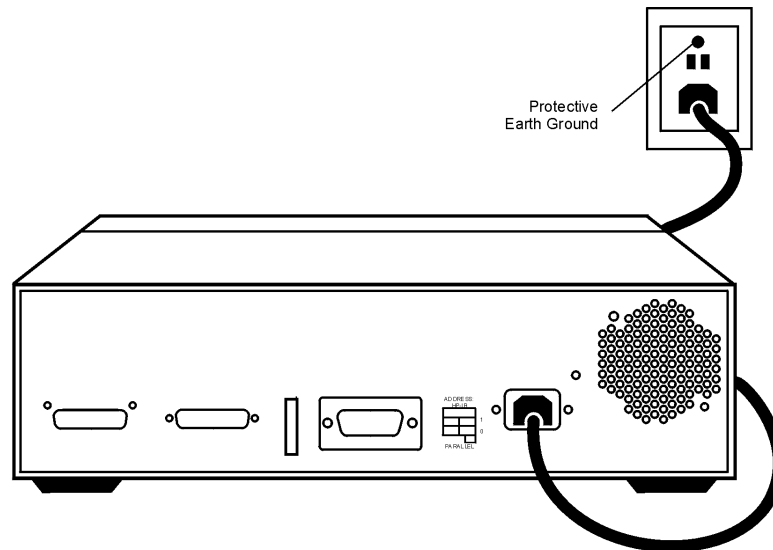

3. If this product is to be powered by autotransformer, make sure the common terminal is connected to the neutral (grounded) side of the ac power supply.

Figure 3 Protective Earth Ground

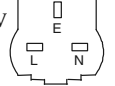

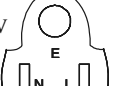
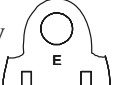
WARNING This is a Safety Class I product (provided with a protective earthing ground incorporated in the power cord). The mains plug shall only be inserted into a socket outlet provided with a protective earth contact. Any interruption of the protective conductor, inside or outside the instrument, is likely to make the instrument dangerous. Intentional interruption of the protective conductor is prohibited.

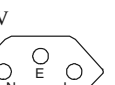
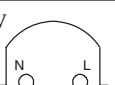
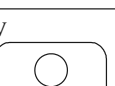
Figure 4 Power Cables

Plug Type ^a	Cable Part Number	Plug ^b Description	Length cm (in.)	Cable Color	For Use in Country
250V 	8120-8705	Straight BS 1363A	229 (90)	Mint Gray	Option 900 United Kingdom, Hong Kong, Cyprus, Nigeria, Singapore, Zimbabwe
	8120-8709	90°	229 (90)	Mint Gray	
250V 	8120-1369	Straight AS 3112	210 (79)	Gray	Option 901 Argentina, Australia, New Zealand, Mainland China
	8120-0696	90°	200 (78)	Gray	
125V 	8120-1378	Straight NEMA 5-15P	203 (80)	Jade Gray	Option 903 United States, Canada, Brazil, Colombia, Mexico, Philippines, Saudi Arabia, Taiwan
	8120-1521	90°	203 (80)	Jade Gray	
125V 	8120-4753	Straight NEMA 5-15P	229 (90)	Gray	Option 918 Japan
	8120-4754	90°	229 (90)	Gray	
250V 	8120-1689	Straight CEE 7/VII	200 (78)	Mint Gray	Option 902 Continental Europe, Central African Republic, United Arab Republic
	8120-1692	90°	200 (78)	Mint Gray	
230V 	8120-2104	Straight SEV Type 12	200 (78)	Gray	Option 906 Switzerland
	8120-2296	90°	200 (78)	Gray	
220V 	8120-2956	Straight SR 107-2-D	200 (78)	Gray	Option 912 Denmark
	8120-2957	90°	200 (78)	Gray	
250V 	8120-4211	Straight IEC 83-B1	200 (78)	Mint Gray	Option 917 South Africa, India
	8120-4600	90°	200 (78)	Mint Gray	
250V 	8120-5182	Straight SI 32	200 (78)	Jade Gray	Option 919 Israel
	8120-5181	90°	200 (78)	Jade Gray	

a. E =earth ground, L = line, and N = neutral.

b. Plug identifier numbers describe the plug only. The Agilent Technologies part number is for the complete cable assembly.

Environmental Preparations

1. Ensure that the “[Power Requirements:](#)” on page 4 are met.
2. If you are installing the test set into a cabinet, ensure there are at least two inches of clearance around the sides and back of the test set and the system cabinet. See [Figure 5](#). The convection into and out of the test set must not be restricted. The ambient temperature (outside the cabinet) must be less than the maximum operating temperature of the test set by 4 °C for every 100 watts dissipated in the cabinet.

Figure 5 Ventilation Clearance Requirements

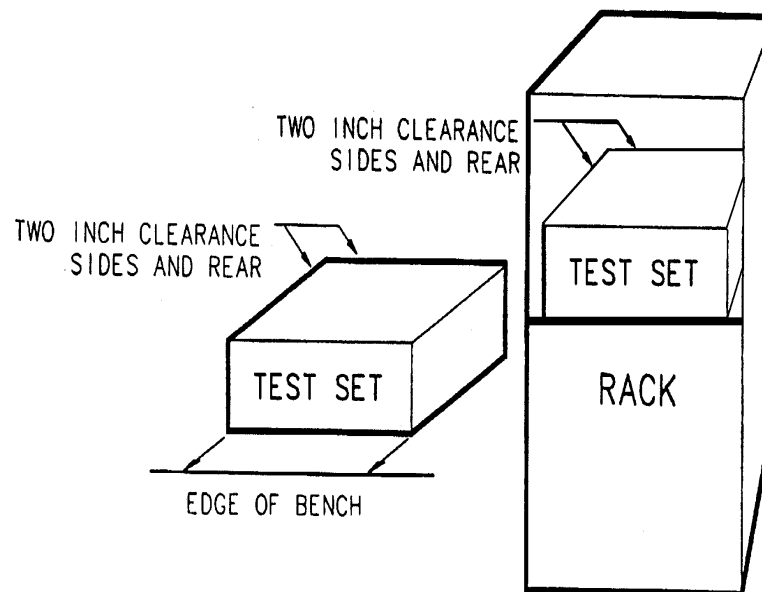

CAUTION

If the total power dissipated in the cabinet is greater than 800 watts, forced convection must be used.

Electrostatic Discharge Protection

Protection against electrostatic discharge (ESD) is essential while removing or connecting cables or assemblies within the network analyzer.

Static electricity can build up on your body and can easily damage sensitive internal circuit elements when discharged. Static discharges too small to be felt can cause permanent damage. To prevent damage to the instrument:

- *always* wear a grounded wrist strap having a 1 M Ω resistor in series with it when handling components and assemblies.
- *always* use a grounded, conductive table mat while working on the instrument.
- *always* wear a heel strap when working in an area with a conductive floor. If you are uncertain about the conductivity of your floor, wear a heel strap.

Figure 6 shows a typical ESD protection setup using a grounded mat and wrist strap.

Figure 6 ESD Protection Setup

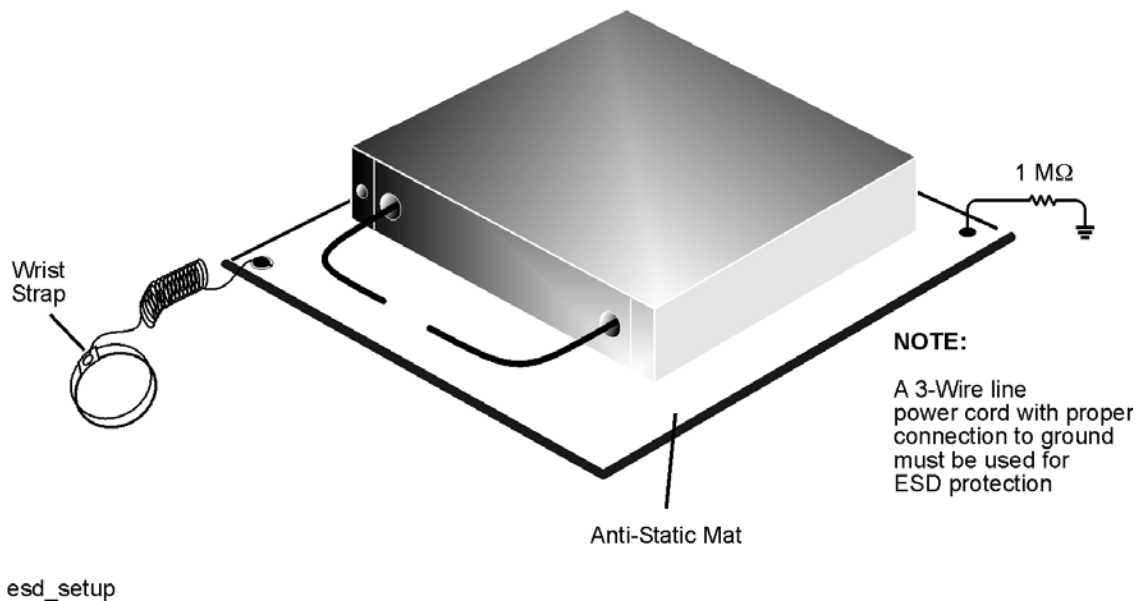

Test Set Familiarization

This section familiarizes the user with various front and rear panel features of the test set.

Front Panel

Figure 7 Front Panel Features

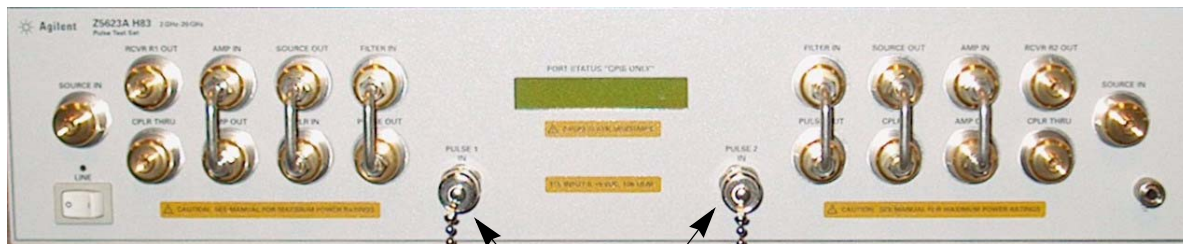

BNC Short (1250-0774)
Attached to Pulse In

Power On Switch

The Power On switch turns the AC power to the test set on and off. The switch is located at the bottom left corner of the front panel.

The switch disconnects the mains circuits from the mains supply after the EMC filters and before other parts of the instrument.

Power LED

The power LED is illuminated when the power switch is in the on (1) position.

RF Connectors

All of the RF connectors are 50 Ω APC 3.5 mm connectors.

Pulse Connector

The pulse input connector is a 50 Ω BNC female connectors.

Rear Panel

Figure 8 Rear Panel Features



Line Module

Line Module

The line module contains the power cable receptacle and the line fuse.

Power Cables

The line power cable is supplied in one of several configurations, depending on the destination of the original shipment.

Each instrument is equipped with a three-wire power cable. When connected to an appropriate ac power receptacle, this cable grounds the instrument chassis. The type of power cable shipped with each instrument depends on the country of destination. See [Figure 4 on page 7](#) for the part numbers of these power cables.

WARNING This is a Safety Class I product (provided with a protective earthing ground incorporated in the power cord). The mains plug shall only be inserted in a socket outlet provided with a protective earth contact. Any interruption of the protective conductor, inside or outside the instrument, is likely to make the instrument dangerous. Intentional interruption is prohibited.

The Line Fuse

The line fuse (F 3 A/250 V, 2110-0780) and a spare reside within the line module. [Figure 9](#) illustrates where the fuses are and how to access them.

Figure 9 Location of Line Fuses

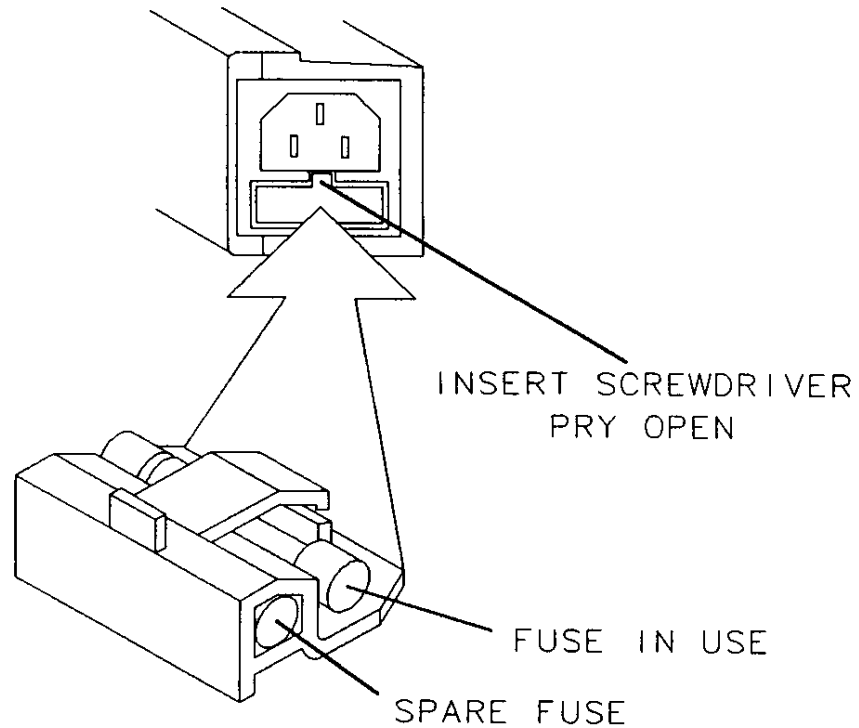

Operation

The Agilent Z5623AH83 Dual Directional Pulse Test Set can be configured differently for many applications. Included in this document are three typical configurations:

- [Figure 11, “Shipped Configuration.”](#)
- [Figure 13, “High Power Forward Direction.”](#)
- [Figure 14, “High Power Dual Directional.”](#)

NOTE The internal firmware of the PNA has not been modified for this test set option. The power levels indicated on the Agilent E8363B and E8364B may differ depending on the user configuration that is chosen.

Refer to the configuration diagrams for external component connections and/or operating constraints when utilizing the high power capability of the Agilent Z5623AH83 Dual Directional Pulse Test Set. External components are not supplied with this option.

When using the Agilent E8362B Series Network Analyzer with Z5623AH83 Dual Directional Pulse Test Set in the bypass or the high power configuration, the PNA Frequency Offset mode (Option 080) and External R1 (Option 081) must be activated. This will ensure phase lock and allow R1 and R2 to receive the new reference power levels from the amplifiers. Refer to [Table 2 on page 14](#).

CAUTION The Z5623AH83 is equipped with reference channel attenuators. These attenuators reduce the RF power to the PNA R1 and R2 receiver ports. The test set attenuators can be set from 0 to 60 dB in 10 dB steps. The recommended power levels to the PNA R1 and R2 receiver ports is -15 dBm. Refer to your PNA specifications to optimize power levels to the receiver ports.

The PNA Option 016, Receiver Step Attenuators, reduces the power to the A and B receivers. The A and B maximum attenuator setting is 35 dB. Power measurements to Test Ports 1 and 2 above $+35$ dBm will require additional attenuation. Add the appropriate amount of attenuation that will keep the coupler arm output power below -15 dBm. Refer to [Table 2 on page 14](#).

CAUTION Hot Switching is not allowed with the Z5623AH83 when making high power measurements or damage to the switch will occur. Hot Switching is the condition when the internal switch or switches are set to a position for making high power measurements, and then set to another position without reducing the power. The maximum power that the switches are allowed to switch states is $+20$ dBm.

CAUTION Prior to powering-up the booster amplifier, it is highly recommended that the user verify the RF power levels seen by the various elements of the test setup. At high power levels a mistake could permanently damage the instrument. Refer to [Table 2 on page 14](#).

Table 2 Power Levels

Test Setup	Power Level
Maximum Z5623AH83 RF Power Levels to Access Ports:	
SOURCE IN	+20 dbm
RCVR R1 OUT, RCVR R2 OUT	+20 dBm
CPLR THRU, CPLR IN, AMP IN	+43 dBm @ 10 MHz to 20 GHz
AMP OUT, SOURCE OUT	+30 dbm
FILTER IN	+30 dBm (dependent on filter)
PULSE OUT	+20 dbm (dependent on filter)
AMP 1 IN TERM, AMP 2 IN TERM	+30 dBm
AMP 1 OUT TERM, AMP 2 OUT TERM	+30 dbm
Maximum PNA RF Power Levels to Access and Test Ports:	
Max Recommended RF Level at A/B/R1/R2 Receivers	- 15 dbm
Damage Level at A/B/R1/R2 Receivers	+15 dbm
Max Recommended RF Level at Port 1, 2 Source	+0 dBm
Damage Level to Port 1, 2 SOURCE OUT	+20 dBm
Max Level to Port 1, 2 Test Ports	+20 dBm

NOTE Refer to your PNA specifications to optimize the power levels in the receivers.

NOTE We recommend that you do *not* operate components near damage or maximum levels. The power levels should be kept at less than 3 dB, preferably 6 dB, below damage and maximum levels.

Figure 10 Maximum Power Levels

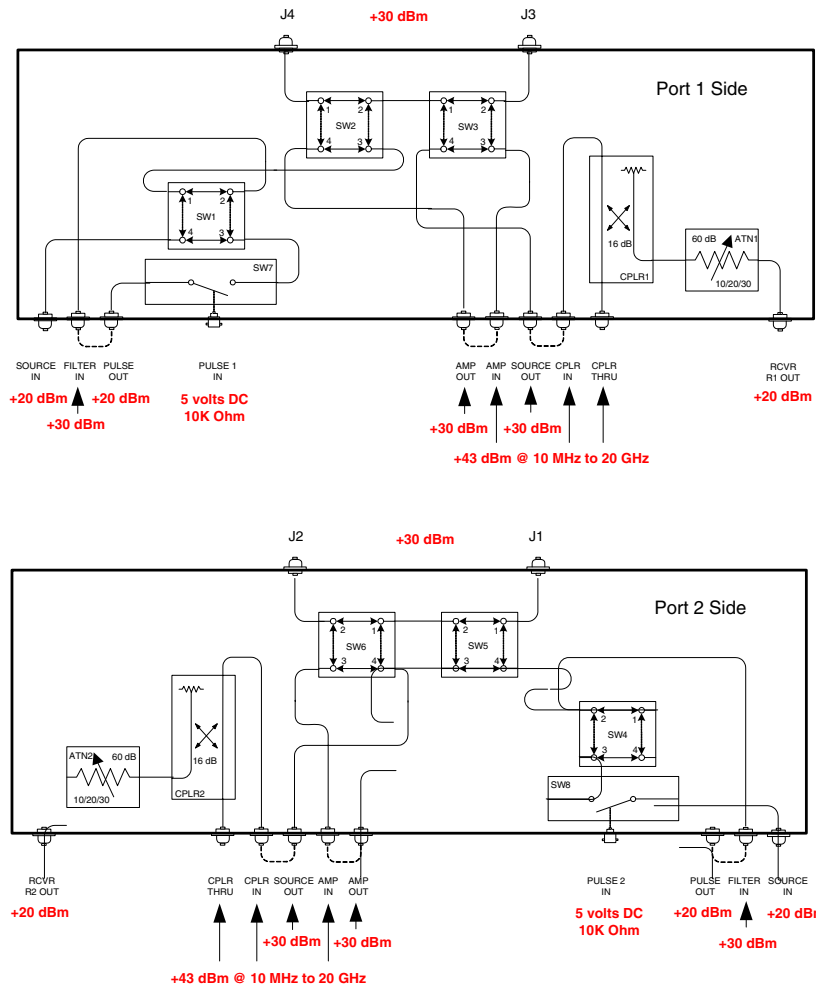
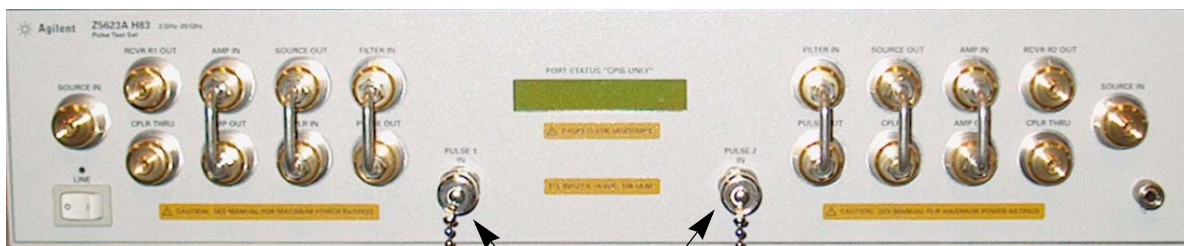

Figure 11 Shipped Configuration



BNC Short (1250-0774)
Attached to Pulse In

System Setup

Figure 12 on page 17 shows the setup configuration of the Z5623AH83 Dual Directional Pulse Test Set and how it should be configured with the PNA and the Pulse Pattern Generators.

1. Connect the following RF Cables:
 - Connect RF Cable (5064-3851 - rack mount) or (5064-3856 - bench mount) from the Test Set RCVR R1 or R2 to the PNA RCVR R1 or R2 IN.
 - Connect RF Cable (5064-3852 - rack mount) or (5064-3857 - bench mount) from the Test Set SOURCE IN to the PNA SOURCE OUT (Ports 1 & 2).
 - Connect RF Cable (5064-3853 - rack mount) or (5064-3858 - bench mount) from the Test Set CPLR THUR to the PNA CPLR THUR (Ports 1 & 2).

NOTE The test set rear panel connections are not shown in [Figure 12 on page 17](#).

2. Connect the external 50 Ω loads (00909-60006) on Test Set RF Ports to J1, J2, J3, and J4.
3. Connect the test set's 37-Pin D-SUB jumpers (Z5623-60202) to the rear panel Port 1 and Port 2 connectors for GPIB and parallel control.
4. Connect the GPIB cable from the PNA, Test Set and Pulse Pattern Generators. (These cables are not supplied).
5. Connect a BNC cable for the 10 MHz Reference between the PNA and the Pulse Pattern Generators. (These cables are not supplied).
6. Connect the four BNC cables from each Pulse Pattern Generators Output 1 and 2 to the PNA rear panel IF Inputs. (These cables are not supplied).
7. Connect two BNC cables from the Test sets PULSE 1 and 2 IN to the Pulse Pattern Generator. (These cables are not supplied).

Figure 12 System Setup Configuration

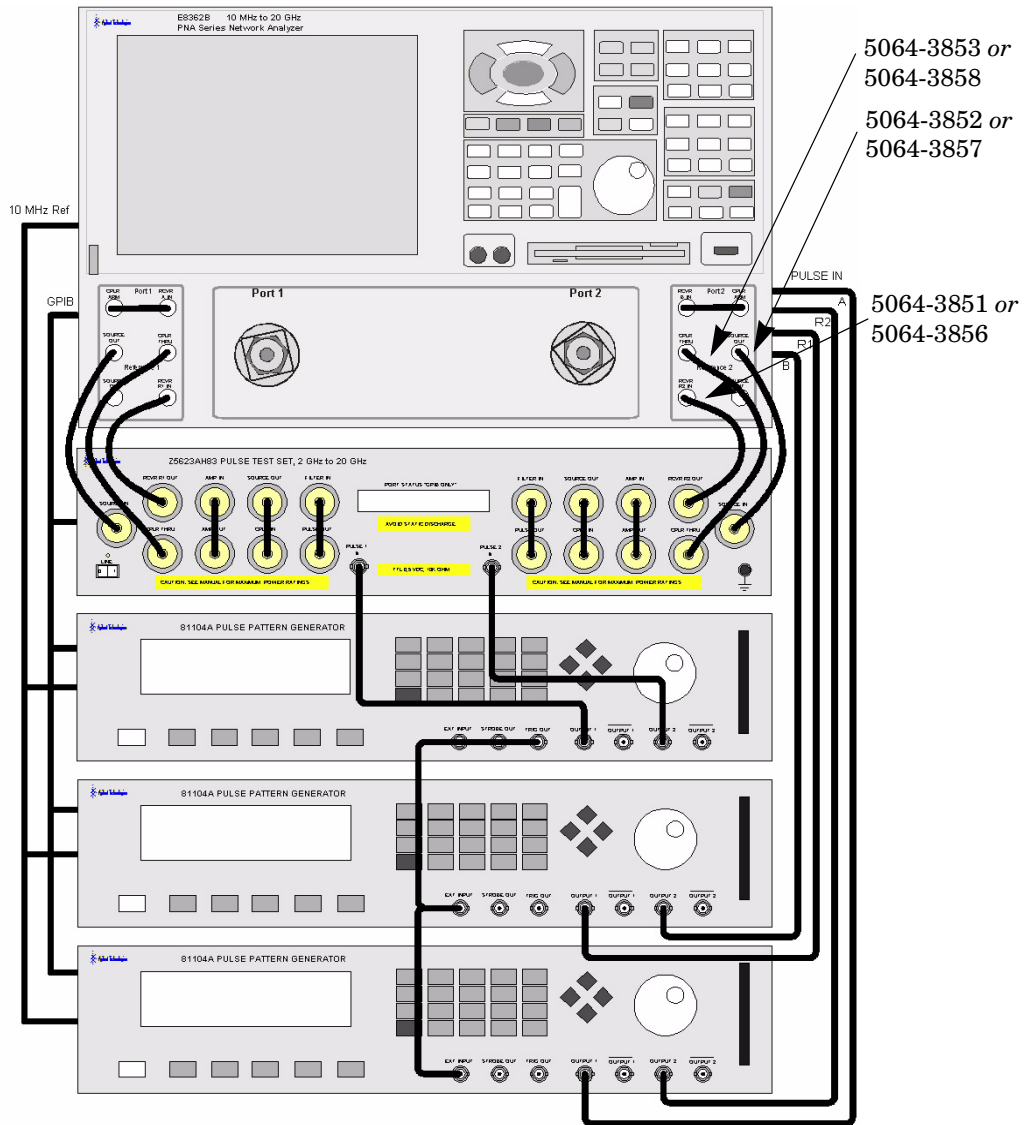

In the following diagrams a high power isolator or attenuator *must* be inserted at the front panel CPLR IN and SOURCE OUT to protect the internal test set modulator PIN switch and the PNA solid state transfer switch (30 dB isolation recommended), or if reverse isolation of the amplifier is less than 30 dB. Maximum power into the modulator PIN switch is 20 dBm for both forward and reverse directions. Optimum power level to all receivers is -15 dBm.

- Insert attenuators (A, B, R1 and R2 ports) to reduce power to the receivers accordingly.
- Set the initial instrument state to -65 dBm test port power level to reduce the risk of damage when powering on the unit.
- The recommended sweep mode is [STEP].
- Frequency Offset mode must be **On** and the R1 reference channel should be set to **External**.

Figure 13 High Power Forward Direction

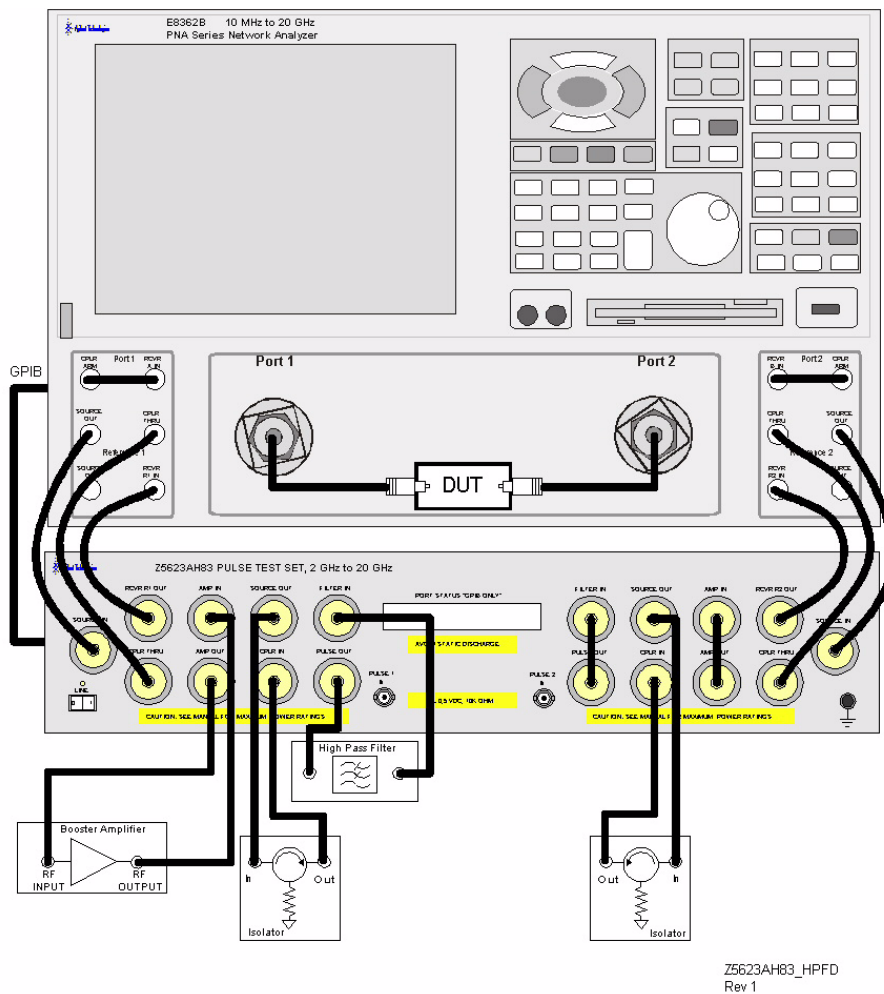
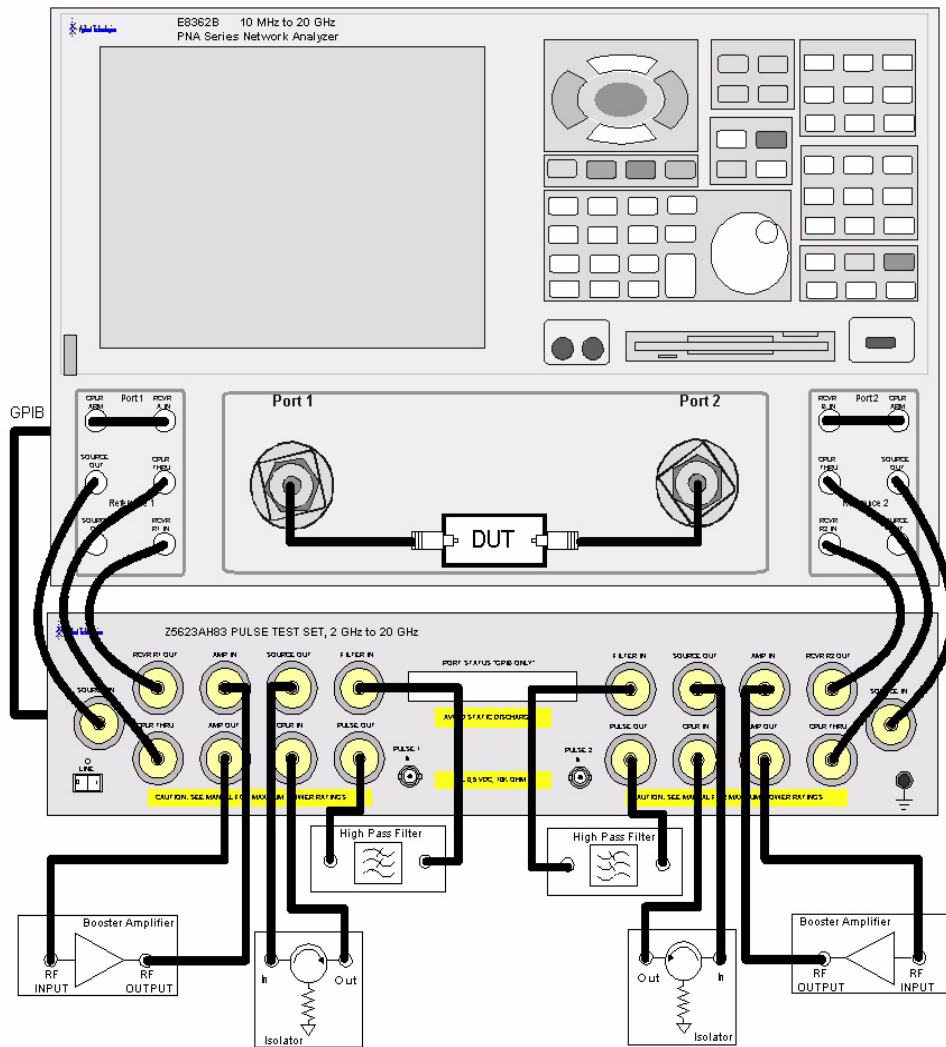

Figure 14 High Power Dual Directional



Pulse Test Set Control Program

Getting Started

Your Z5623A Pulse Test Set, comes with a Pulse Control Program disk, (Z5623-10014, Disk 1 of 1). This disk is in a DOS high density format and can be inserted directly into the PNA disk drive. Your PNA must have revision 6.0 PNA firmware and XP operating system installed so that the Pulse Test Set Control Program can be installed.

1. You can verify your PNA operating system by navigating to the PNA desktop. Right-click the My Computer icon. A drop-down menu will appear. Refer to [Figure 15](#).

Figure 15 **Desk Top Properties**

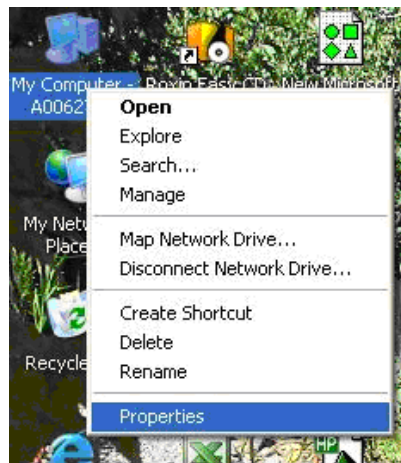

2. Select **Properties** in the drop-down menu. The System Properties will appear. Refer to [Figure 16](#).

Figure 16 **XP OS**



3. If your analyzer does not have the XP OS stop, you will need to upgrade the PNA with the N8990A. This option will install a new CPU and the XP operating system.

Pulse Control Program Installation

The Pulse Control Program disk has the file to control the Pulse Test Sets. It is found by navigating to the A:\ (floppy drive) after the Control Program diskette has been inserted into the PNA disk drive. Refer to [Figure 17](#).

Figure 17 **Disk Program Files**



Agilent PNA Pulse Test Set Control_msi

1. Using Windows Explorer, navigate to the C:/Program Files directory to verify that a “temp” directory exists. If not, create one by right-clicking within the Program Files folder then select **New > Folder** and name it “temp”. Once the **temp** directory is created or located, insert the Pulse Control Program disk into the PNA disk drive. Copy the desired file listed above into the **temp** folder from the A:\(floppy drive) to the C:\Program Files**temp** folder. Refer to [Figure 18](#).

Figure 18 **Temp Folder**

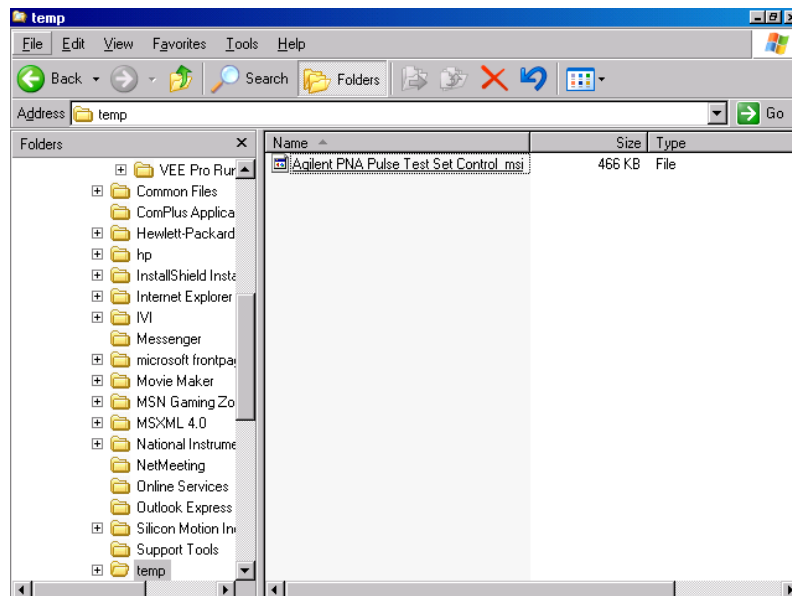

2. The file copied into the **temp** directory must be renamed to function. The file has an underscore “_” between Control_msi. Replace the underscore with a period “.” Highlight the file name, right click and select rename.

3. Once the file has been renamed, double-click on the file to start the installation. The Setup Wizard will appear in the display.
4. Press **Next**. The Selection Installation folder will appear. Refer to [Figure 19](#).

Figure 19 Installation Start

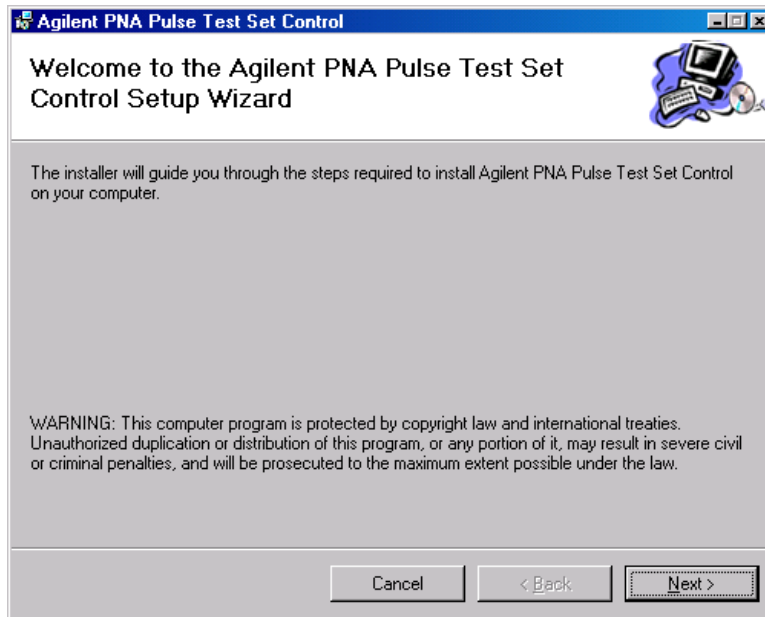

5. Press **Next** for default or to modify where to install the folder. Refer to [Figure 20](#).

Figure 20 Folder Selection

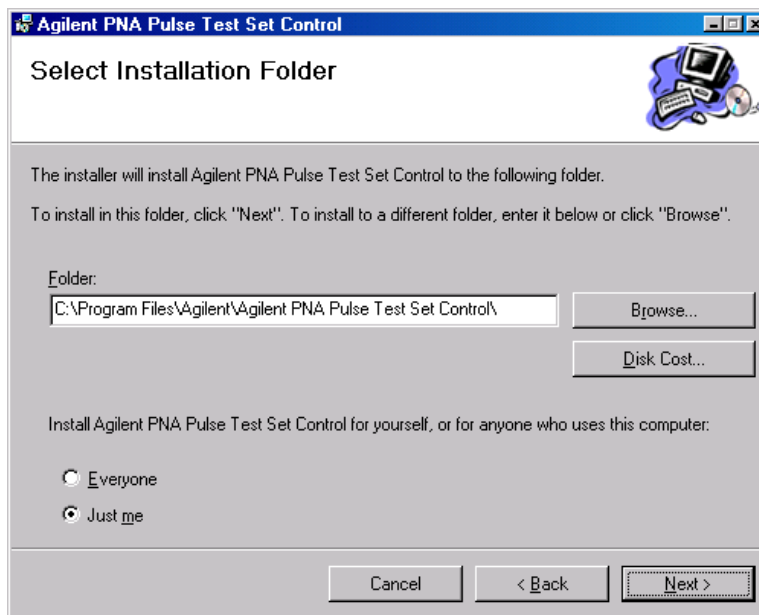

6. Press **Next** to confirm the installation. Refer to [Figure 21](#).

Figure 21 **Confirm Installation**

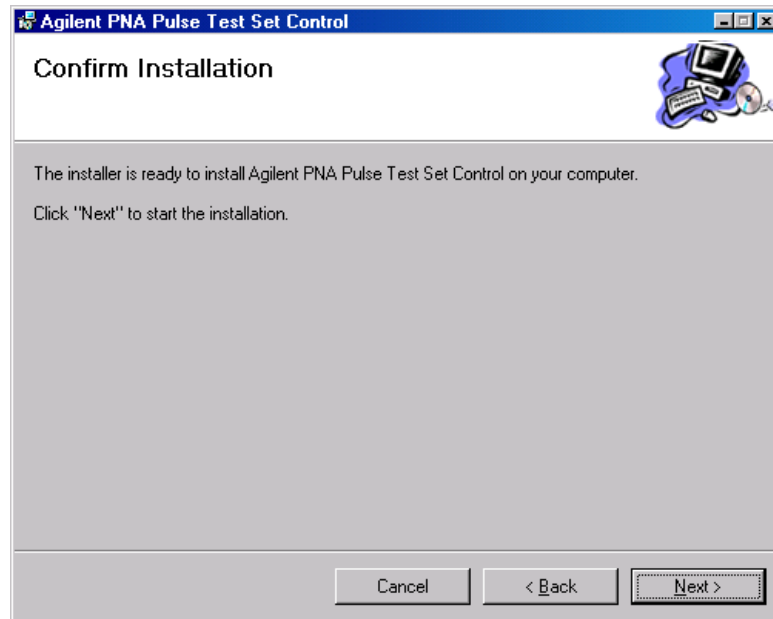

7. Press **Close** to complete the installation. Refer to [Figure 22](#).

Figure 22 **Installation Complete**

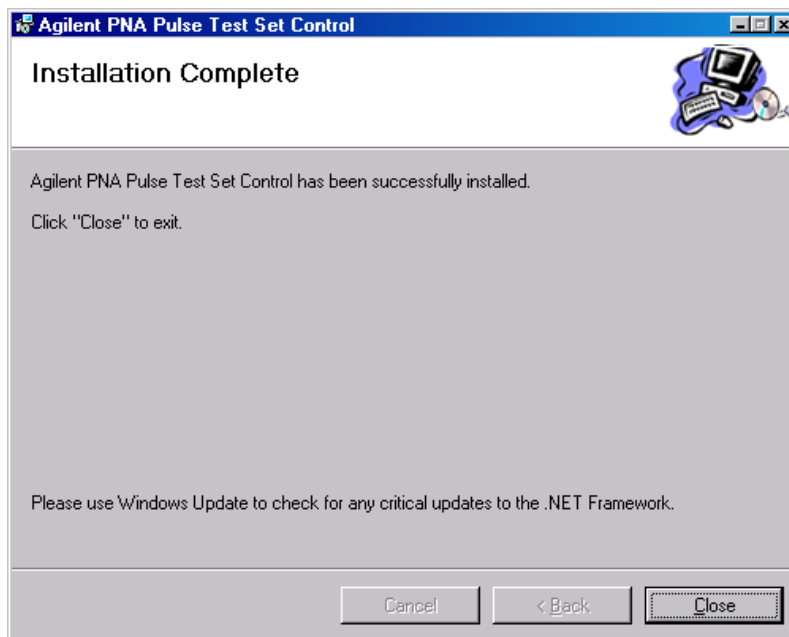

Accessing the Program

The program installed will be located in its own file folder:

C:\Program Files\Agilent\Agilent PNA Pulse Test Set Control

1. Locate the file directory. Refer to [Figure 23](#).
2. Select the **Agilent PNA Pulse Test Set Control** folder. Refer to [Figure 23](#).

Figure 23 **Locate the Folder**

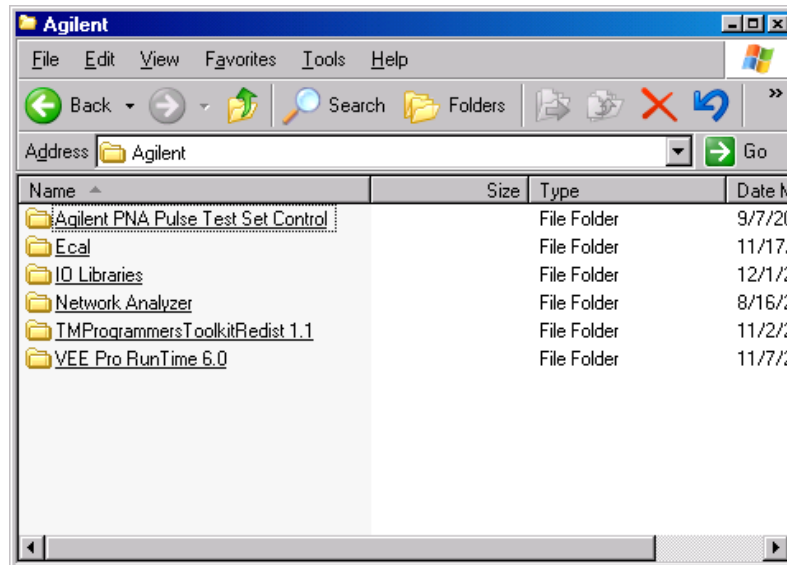

3. Double-click **PulseTestSetControl.exe** file. Refer to [Figure 24](#).

Figure 24 **PulseTestSetControl.exe**

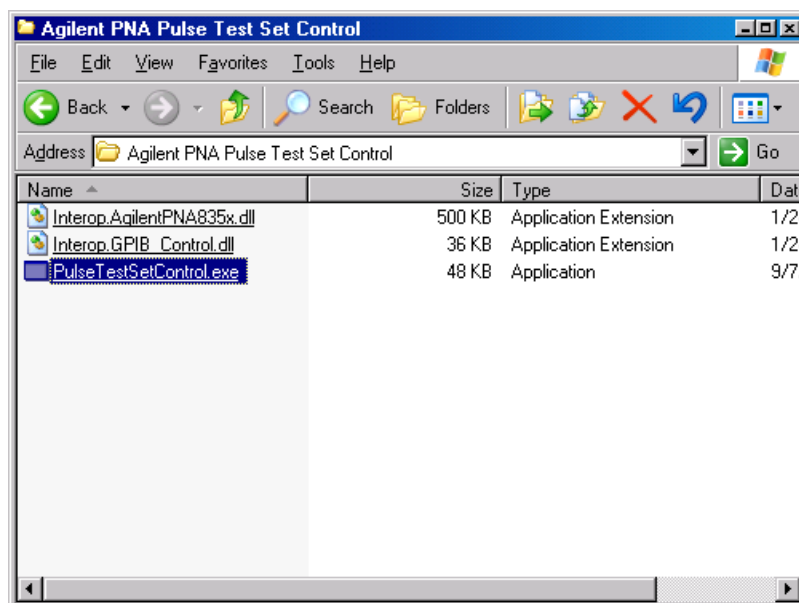

Once the file has been executed the Agilent Pulse Test Set Control panel will appear. The control panel shown in [Figure 25](#) is for Option H86 that has the forward direction (Port 1) only and therefore, the Port 2 controls are not selectable. For the dual direction models both port controls will be active.

Figure 25 **Control Panel**

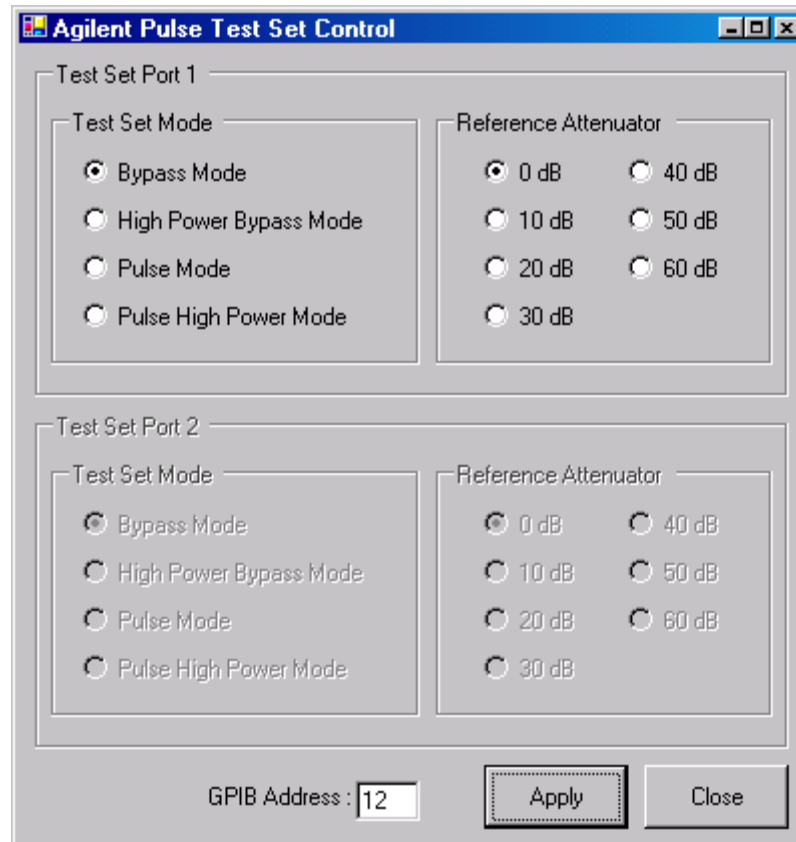

Control Panel Features

The control panel is used to set the operation mode of the test set to the user's requirements.

These features are listed in the user manual for the Pulse Test Set.

As outlined in the manual switching between Bypass/Pulse Modes to High Power Modes can damage the test set and PNA if care is not taken.

Test Mode of Operation

- Bypass Mode - PNA in its normal operation
- High Power Mode - Allows the user to insert source amplifiers
- Pulse Mode - Accesses the pin switch modulator
- Pulse High Power Mode - Accesses the pin switch modulator and allows the user to insert amplifiers

Reference Attenuator

- Allows the user to select between 0 to 60 dB in 10 dB steps the amount of attenuation to the reference channel for high power applications.

GPIB Address

- The address of the Pulse Test Set. Default is 712. Only the last two digits are required.

Controlling the Test Set

The Agilent Z5623AH83 is considered a “slave” instrument. A Controller must be used to control the test set. There are four ways to control the test set:

- The PNA can be used as the controller to talk to the test set over the GPIB.
- A Controller can directly talk to the test set over the GPIB.
- The Parallel port can be used to set the test set.
- Direct control access to the internal switches and attenuators via open collector lines to ground the input lines.

Commands

As mentioned before, the test set can be controlled in four ways. The first two involve the use of a separate computer. The third way uses parallel port manually. The fourth control method uses direct access from two rear panel 37 pin D-Sub connectors.

NOTE The 37 pin D-Sub jumpers (Z5623-60202) must be attached to the test sets Port 1 and 2 rear panel direct access connectors for the GPIB and parallel port commands to work. These connectors are not connected to the test set when they are shipped.

Typeface Key Conventions

The following key conventions are used throughout this document.

- **[HARDKEYS]** are labeled front panel keys.
- **SOFTKEYS** are unlabeled key whose function is indicated on the instrument display.

PNA Control

Write the GPIB commands from the PNA directly to the Z5623AH83 test set GPIB port located on the rear panel. The following example assumes that the address of the test set is set to 12. Be sure to use an ending semi-colon.

The PNA must be setup as the Controller first.

1. Select **System > Configure > SICL/GPIB > System Controller**. Press **OK** and close the window.

Figure 26 SICL/GPIB

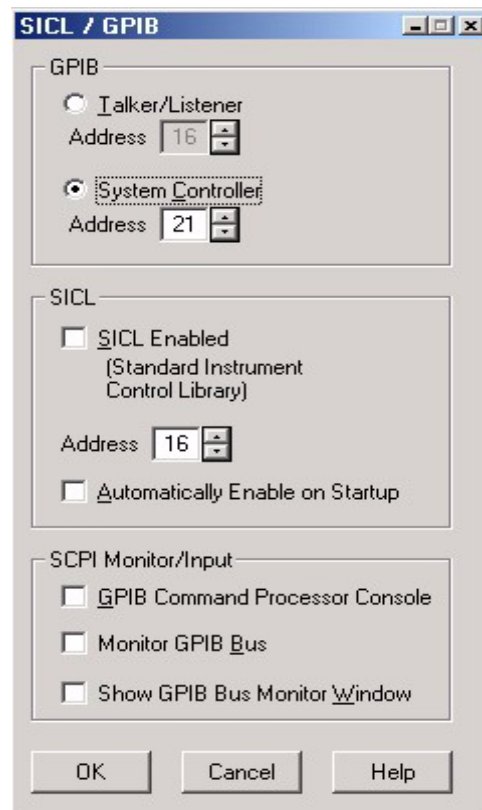

2. Launch the **Measurement & Automation** icon located on the PNA desk top.
3. Expand **Devices and Interfaces**.
4. Right click on **GPIB0 (AT-GPIB/TNT)** and select **Interactive control**. When the new window appears at the prompt type the following:

: ibdev (This command sets up the PNA GPIB to talk to the Z5623AH83 test set)

```
enter board index: 0
enter primary address: 12
enter secondary address: 0
enter timeout: 0
enter 'EOI on last byte' flag: 1
```

ibwrt: "command\$;" (Command\$ is the string the user would get from the table.)

Figure 27 Interactive Control

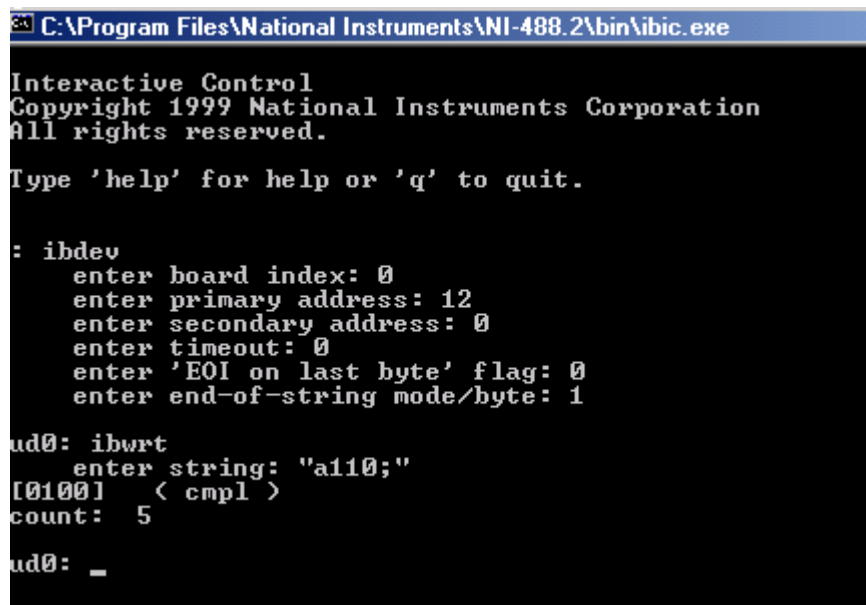

```

C:\Program Files\National Instruments\NI-488.2\bin\ibic.exe
Interactive Control
Copyright 1999 National Instruments Corporation
All rights reserved.
Type 'help' for help or 'q' to quit.

: ibdev
  enter board index: 0
  enter primary address: 12
  enter secondary address: 0
  enter timeout: 0
  enter 'EOI on last byte' flag: 0
  enter end-of-string mode/byte: 1

ud0: ibwrt
  enter string: "a110;"
[0100]  < cmpl >
count: 5
ud0: _

```

Addressing Directly

Write GPIB commands from the controller to write commands directly to the Z5623AH83 test set GPIB port located on the rear panel. The following RMB example assumes that the address of the test set is set to 712.

RMB

```
OUTPUT 712;"command$;"
```

To query and read from the Z5623AH83 test set, the user needs to send two commands. The first queries the test set for an individual switch count, and the second reads the data as a string. Be sure to use an ending semi-colon. See your manual regarding details for switching the identifier.

```
OUTPUT 712;"sw10?;"!Query test set for switch 10
```

```
ENTER 712;"Count$;" !Read switch 10 Count
```

To query and read from the Z5623AH83 test set ID, the user needs to send two commands. The first queries the test set for an ID, and the second reads the data as a string. See your manual for details for “ID Identifier read.”

```
OUTPUT 712;"idn?;"!Query test set for ID
```

```
ENTER 712;"Name$;"!Read test set ID
```

VEE

When using VEE be sure the Direct I/O is set as follows. This is also the default Direct I/O settings.

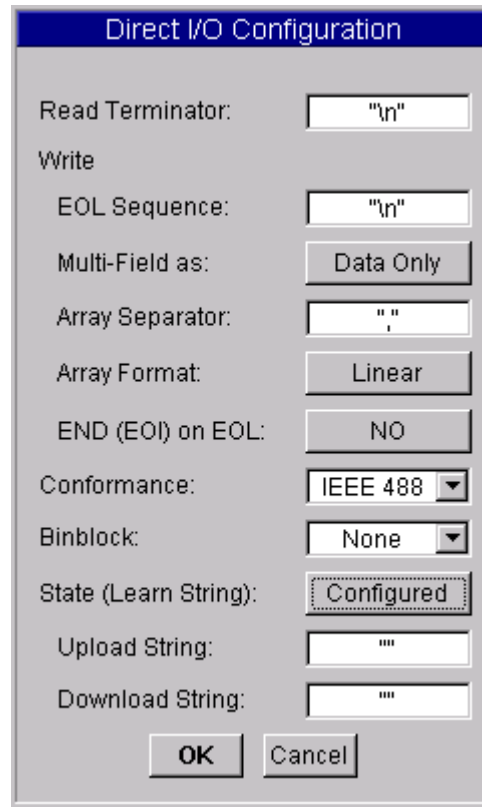
Figure 28 Direct I\O

The image shows a dialog box titled "Direct I/O Configuration". It contains several settings for Direct I/O operations:

- Read Terminator:
- Write
 - EOL Sequence:
 - Multi-Field as:
 - Array Separator:
 - Array Format:
 - END (EOI) on EOL:
- Conformance: (dropdown arrow)
- Binblock: (dropdown arrow)
- State (Learn String): (dotted border)
- Upload String:
- Download String:

At the bottom of the dialog are two buttons: and .

To send commands to test set configure the I/O Transaction as follows.

Figure 29 I/O Transaction

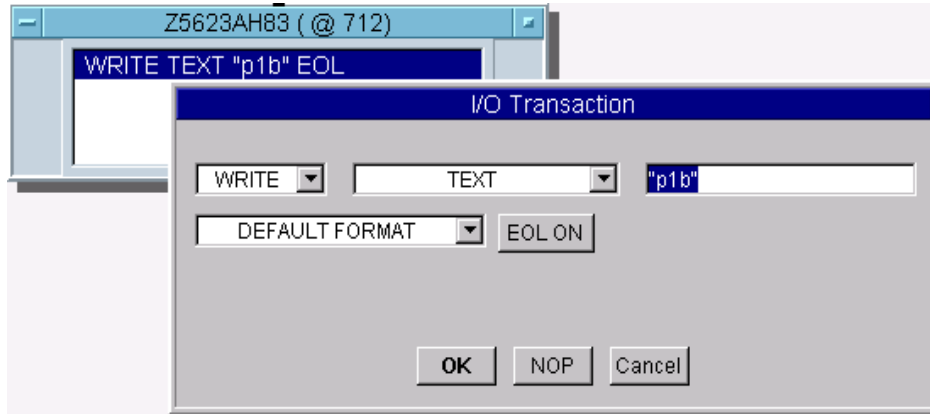

Querying and read from the test set is the same for both switch count and box ID.

Figure 30 Query/Read

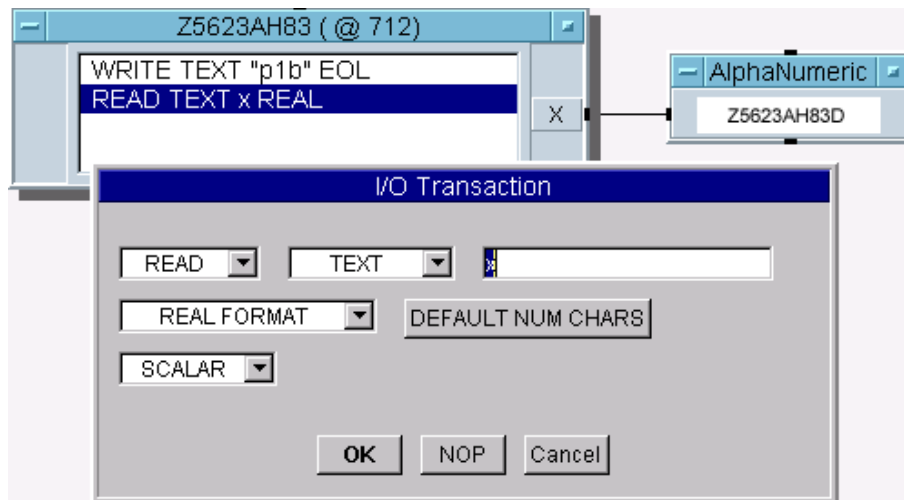

Quick Basic

If you are using Quick Basic or Visual Basic, be sure to disable EOI and EOL before sending commands to the test set. Including the semicolon in program commands will not ensure that these commands are disabled as would be the case in HP Basic/RMB. When using the 82335 GPIB Interface and Visual Basic, use the following commands to disable EOI and EOL, send the necessary data to the test set, and re-enable EOI and EOL.

NOTE Be sure to re-enable EOI and EOL before sending data to another instrument.

Write Commands

```
GpibEoi(hGpib;7,0) 'disable EOI
GpibEol(hGpib;7, "",0) 'disable EOL
GpibOutputs(hGpib;712,info$,length%) 'send command to test set.
GpibEol(hGpib;7,chr$(13)+chr$(10),2) 're-enable EOL and set to
chr$(13)+chr$(10)
GpibEoi(hGpib;7,1,) 're-enable EOI where hGpib specifies the handle
returned by GpibOpen
```

Read Commands

```
info$ = "sw10?" 'query sw10 for switch count
length% = len(info$) 'length of command
max.len% =10 'max length data form idn? or swxx? function
infi$ = space$(max.len%)
GpibEoi(hGpib;7,0) 'disable EOI
GpibEol(hGpib;7, "",0) 'disable EOL
GpibOutputs(hGpib%,712,info$,length%) 'send query command to tests
set.
GpibEnters(hGpib%,712,infi$,max.len%) 'get data from tests set.
GpibEol(hGpib;7,chr$(13)+chr$(10),2) 're-enable EOL
GpibEoi(hGpib;7,1,) 're-enable EOI
```

National Instruments VISA

If you are using National Instruments VISA, be sure to set the variables as follows:

`VI_ATTR_SEND_END_ENVI = FALSE` ` This specifies whether to assert END during the transfer of the last byte of the buffer.

`VI_ATTR_TERMCHAR = 0x0A` ` This is the termination character. When the termination character is read and `VI_ATTR_TERMCHAR_EN` is enabled during a read operation, the read operation terminates.

`VI_ATTR_TERMCHAR_EN = VI_TRUE` ` This is a flag that determines whether the read operation should terminate when a termination character is received.

`VI_ATTR_SUPPRESS_END_EN = VI_FALSE` ` This specifies whether to suppress the END bit termination. If this attribute is set to `VI_TRUE`, than the END bit does not terminate read operations. If this attribute is set to `VI_FALSE`, than the END bit terminates read operations.

Write Commands:

Append all commands with `\n`. For example; `*rst\n`

Read Commands:

The test set returns data terminated by `\r\n`. For example the query `sw10?\n` returns `00000010\r\n`.

Parallel Port

The third way is used by the service center or during production to verify the port path connections. This uses the parallel port on the rear panel of the Z5623AH83. This method uses an 8722ES Network Analyzers Parallel port to control the test set. The following example assumes that the address of the network analyzer is set to 16. Be sure to use an ending semi-colon.

```
OUTPUT 716; "PARALGPIO" (Sets the parallel port for GPIO function).
OUTPUT 716; "PARAOUT[D]; (Programs all GPIO output bits (0 to 256) at once).
```

Table 3 GPIB and Parallel Commands

GPIB	Description	LCD Display	Parallel	Decimal
A100	RCVR R1 Attenuator 0 dB	A00	00000000	0
A110	RCVR R1 Attenuator 10 dB	A10	00000001	1
A120	RCVR R1 Attenuator 20 dB	A20	00000010	2
A130	RCVR R1 Attenuator 30 dB	A30	00000011	3
A140	RCVR R1 Attenuator 40 dB	A40	00000100	4
A150	RCVR R1 Attenuator 50 dB	A50	00000101	5
A160	RCVR R1 Attenuator 60 dB	A60	00000110	6
A200	RCVR R2 Attenuator 0 dB	A00	00000111	7
A210	RCVR R2 Attenuator 10 dB	A10	00001000	8
A220	RCVR R2 Attenuator 20 dB	A20	00001001	9
A230	RCVR R2 Attenuator 30 dB	A30	00001010	10
A240	RCVR R2 Attenuator 40 dB	A40	00001011	11
A250	RCVR R2 Attenuator 50 dB	A50	00001101	12
A260	RCVR R2 Attenuator 60 dB	A60	00001110	13
P1B	Port 1 Bypass Mode	P1 Bypass Axx	00001110	14
P1HPB	Port 1 High Power Mode	P1 HP Bypass Axx	00001111	15
P1HPP	Port 1 High Power Pulse Mode	P1 HP Pulse Axx	00010000	16
P1P	Port 1 Pulse Mode	P1 Pulse Axx	00010001	17
P2B	Port 2 Bypass Mode	P2 Bypass Axx	00010010	18
P2HPB	Port 2 High Power Mode	P2 HP Bypass Axx	00010011	19
P2HPP	Port 2 High Power Pulse Mode	P2 HP Pulse Axx	00010100	20
P2P	Port 2 Pulse Mode	P2 Pulse Axx	00010101	21
*RST	Reset (Port 1 and 2 Bypass Mode)	P1 Bypass A00 P2 Bypass A00	00010110	22
Display		Description (GPIB)		
IDN?	Z5623AH83D	Read Test Set ID		
	ERR: invalid command	Non GPIB or Parallel Command Sent		

Direct Control

The fourth method to control the test set uses the Port 1 and Port 2, 37 pin D-Sub connectors located on the rear panel. Removing the jumper connectors (Z5623-60202) will allow the user to control the internal switches and attenuators. Refer to [Table 4 on page 40](#) which shows the pinout and function for Port 1 and Port 2.

NOTE	LCD indicator is only valid when the test set is used in control methods; PNA, Controller, and Parallel. Direct control does not change the LCD indicator when either the switches or attenuators are repositioned.
-------------	---

Controlling the Switches

Control of the internal switches directly, is provided from the 37 pin D-Sub connector and can be done in two ways.

- TTL
- Open Collector

The TTL input allows the user independent switch position control by either a low (0) or high (1). The TTL voltage is 0 or 5 volts. The [Figure 31 on page 37](#). The 37 Pin D-Sub connector shows the rear panel input/output configuration for Port 1. Port 2 is identical to Port 1 but where SW1 is replace by SW4, SW2 is replace by SW5, SW3 is replace by SW6 on the RF block diagram. Pins 5, 12, 22 are the TTL input pins. Pin 5 controls SW1 or SW4, pin 12 controls SW3 or SW6, and pin 22 controls SW2 or SW5.

The Open Collector inputs allows the user to control a switch position by grounding either the A (AD) or B (BD) drive input lines for each switch. Only one of these two input lines can be grounded at any given moment. Recommended is break before making when the input line position changes. Refer to [Figure 31](#). The 37 Pin D-Sub connector shows the rear panel input/output configuration for port 1. Port 2 is identical to port 1 but where SW1 is replace by SW4, SW2 is replace by SW5, SW3 is replace by SW6 on the RF block diagram. Pins (1,2), (8,9), and (25,26) are the A and B drives input pins. Pins 1, 2 control SW1 or SW4, pins 8, 9 control SW3 or SW6, and pins 25, 26 control SW2 or SW5.

Switch Indicators

The internal switch positions can be read only when used in the Direct Control method. A switch position can be read by either a low (0) or high (1) on the A (AI) or B (BI) indicator lines. The voltage is either 0 or 5 volts depending on the switch position. Low (0) indicates disabled, and high (1) indicates enabled. [Figure 31](#) shows the rear panel input/output configuration for port 1. Port 2 is identical to port 1 but where SW1 is replace by SW4, SW2 is replace by SW5, SW3 is replace by SW6 on the RF block diagram. Pins (3,4), (10,11), and (23,24) are the A and B indicator output pins. Pins 3, 4 indicate SW1 or SW4 position, pins 10, 11 indicate SW3 or SW6 position, and pins 23, 24 indicate SW2 or SW5 position. [Figure 32 on page 37](#) shows how each switch is configured.

Figure 31 37 Pin D-Sub Connector

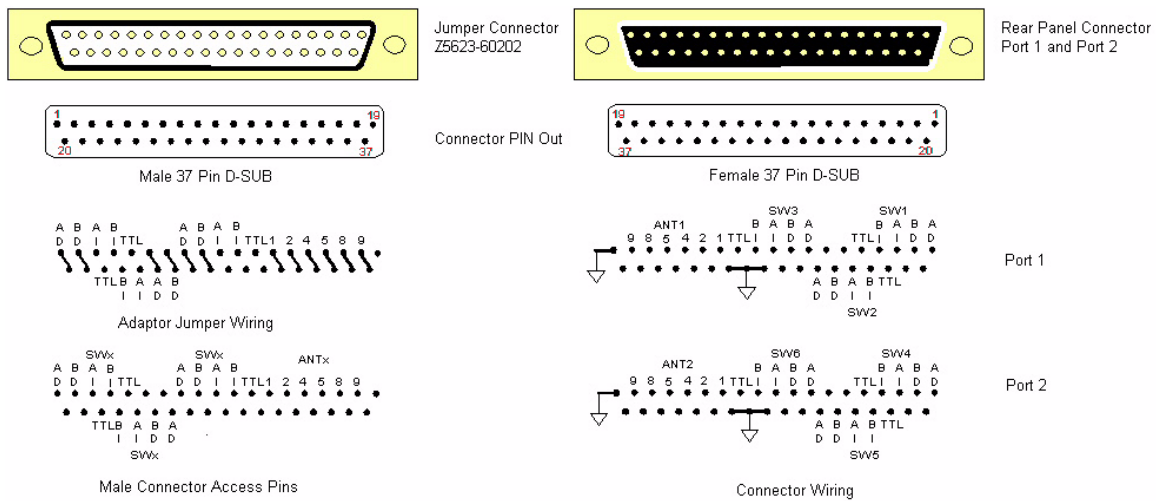
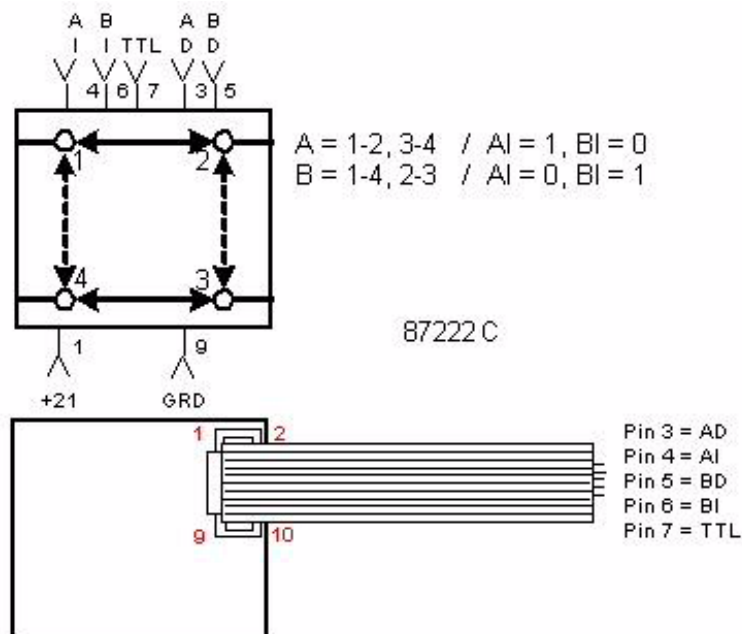

Figure 32 Switch Connection



Switch Indicator Function

The 87222C is set to the A or B Position. See [Table 5 on page 41](#), Switch Indicator Voltages for Test Set Modes. When the switch is set to the A position the Indicator Common is connected, completing the A Indicator path. The 21 VDC connected to the Indicator Common is connected to ground by two resistors (30 k Ω and 10 k Ω). The Position A and B Indicators have independent 10 k Ω resistors to ground. The measured voltage from Position A Indicator to ground is approximately 5 Volts VDC and the Position B Indicator will measure 0 Volts. When the switch is set to Position B, the Indicator common is connected. Measuring the voltage from Position B Indicator to ground will measure approximately 5 Volts VDC and the A indicator will measure 0 Volts.

Example 1 A Indicator Position Connected

- Resistance Indicator Common in a connected path = 40 k Ω
- Resistance between the Indicator Common and Position A when connected = 30 k Ω
- Resistance between Position A and ground = 10 k Ω
- Resistance between the Indicator Common and Position B when connected = OPEN
- Resistance between Position B and ground = 10 k Ω
- $I = V/R = 21/40 \text{ k}\Omega = 0.525 \text{ mA}$
- Voltage drop across 30 k Ω resistor: $V = I \times R = 0.525 \text{ mA} \times 30 \text{ k}\Omega = 15.75 \text{ Volts}$
- Voltage drop across 10 k Ω resistor: $V = I \times R = 0.525 \text{ mA} \times 10 \text{ k}\Omega = \text{Position A indicator to ground} = 5.25 \text{ Volts}$

Being that the Position B switch to the Indicator Common is open, only the 10 k Ω resistor ground is connected providing a pull down on the Position B Indicator pin, effectively grounding it.

Figure 33 Switch Indicator Status

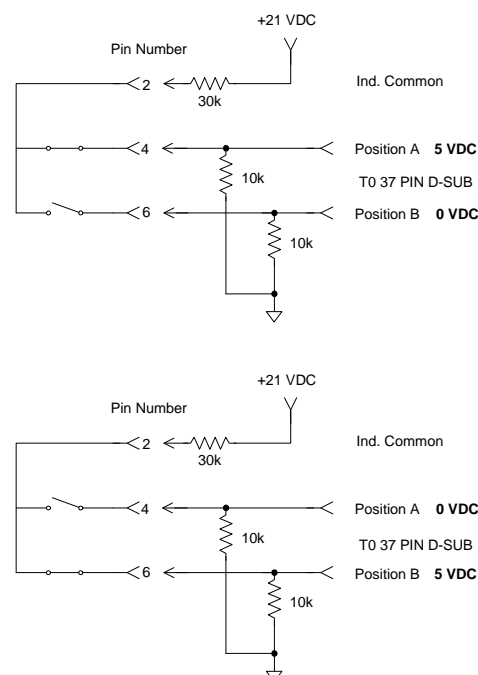

Controlling the Attenuators

Controlling the attenuators are identical to the Switch Open Collector control method.

Figure 31 on page 37 shows the rear panel input/output configuration for Port 1. Port 2 is identical to port 1, but ANT1 is replace by ANT2. Pins 13-18 control the attenuator. Like the switch open collector lines, brake before making the attenuator bypass or select setting changes.

CAUTION Always break before making a selection when using the Open Collector control inputs for the switches and attenuators. Failure to do so can damage the internal switches or attenuators.

CAUTION Ensure that all inputs are off before making any connection. Turn off the test set before removing the connector jumper. Make the rear panel Direct Control connections while the test set is off. Failure to do so can damage the internal switches or attenuators.

Pin	Description
13	10 dB bypass
14	10 dB select
15	30 dB bypass
16	20 dB bypass
17	20 dB select
18	30 dB bypass

Figure 34 Attenuator Connection

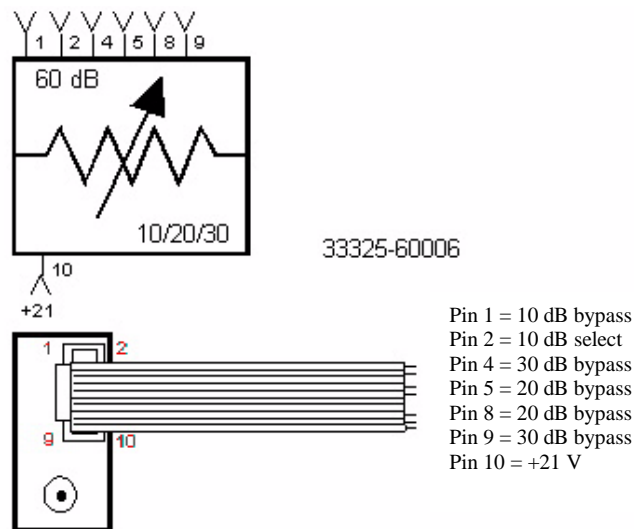

NOTE Switches and attenuators supply voltage is supplied internally by the test set. The supply voltage is 21 Vdc.

NOTE LCD indicator is only valid when the test set is used in the following control methods; PNA, Controller, Parallel. Direct Control does not change the LCD indicator when the switches or attenuators are repositioned.

Table 4 Rear Panel Connection for Port 1 and Port 2

Pin #	Switch	Function	Port 1	Port 2	Description	Switch Position	Pin Bias Switch Control
1	1&4	AD	SW1	SW4	Position A Drive	1 to 2; 3 to 4	1=gnd; 2=OPEN
2	1&4	BD	SW1	SW4	Position B Drive	1 to 4; 2 to 3	1=OPEN; 2=gnd
3	1&4	AI	SW1	SW4	Position A Indicator	A= 5 volts; B	
4	1&4	BI	SW1	SW4	Position A Indicator	A= 0 Volts; E	
5	1&4	TTL	SW1	SW4	TTL Drive	A=High; B=Low	A=5V; B=gnd
26	1&4	AD	SW2	SW5	Position A Drive	1 to 2; 3 to 4	1=gnd; 2=OPEN
25	2&5	BD	SW2	SW5	Position B Drive	1 to 4; 2 to 3	1=OPEN; 2=gnd
24	2&5	AI	SW2	SW5	Position A Indicator	A= 5 volts; B	
23	2&5	BI	SW2	SW5	Position A Indicator	A= 0 Volts; E	
22	2&5	TTL	SW2	SW5	TTL Drive	A=High; B=Low	A=5V; B=gnd
8	2&5	AD	SW3	SW6	Position A Drive	1 to 2; 3 to 4	1=gnd; 2=OPEN
9	3&6	BD	SW3	SW6	Position B Drive	1 to 4; 2 to 3	1=OPEN; 2=gnd
10	3&6	AI	SW3	SW6	Position A Indicator	A= 5 volts; B	
11	3&6	BI	SW3	SW6	Position A Indicator	A= 0 Volts; E	
12	3&6	TTL	SW3	SW6	TTL Drive	A=High; B=Low	A=5V; B=gnd
Pin #	Attenuator	Function	Port 1	Port 2	Description	Attenuator Position	Pin Bias Atten Control
13	1&2	10 OUT	Atten1	Atten2	10 dB Bypass	0	13=gnd; 14=OPEN
14	1&2	10 IN	Atten1	Atten2	10 dB Select	10	13=OPEN; 14=gnd
15	1&2	30 OUT	Atten1	Atten2	30 dB Bypass	0	15=gnd; 18=OPEN
16	1&2	20 OUT	Atten1	Atten2	20 dB Bypass	0	16=OPEN; 17=gnd
17	1&2	20 IN	Atten1	Atten2	20 dB Select	20	16=gnd; 17=OPEN
18	1&2	30 IN	Atten1	Atten2	30 dB Select	30	15=gnd; 18=OPEN

Table 5 **Switch Indicator Voltages for Test Set Modes**

VDC	SW1		SW2		SW3		SW4		SW5		SW6	
	AI	BI	AI	BI	AI	BI	AI	BI	AI	BI	AI	BI
Bypass	0	5	0	5	0	5	0	5	0	5	0	5
HP Bypass	0	5	5	0	5	0	0	5	5	0	5	0
Pulse	5	0	0	5	0	5	5	0	0	5	0	5
HP Pulse	5	0	5	0	5	0	5	0	5	0	5	0

NOTE Indicator position voltages are influenced by the user's interface. High impedance, sensor, or TTL input may be used to monitor the indicator position lines.

Making High Power Measurements With Option H83

The Z5623AH83 and PNA with Options 014, 016, 080, 081, and UNL or H85 can be configured to measure high power devices. This ability is useful if the required power for the device under test is greater than the analyzer can provide, or if the maximum output power from an amplifier under test exceeds safe input limits for a test set and analyzer. This section describes how to set up the analyzer to perform high power measurements.

Initial Setup

1. Turn off all of the equipment. Be sure that the jumpers between the PNA and test sets RCVR 1, RCVR 2, and CPLR THUR are disconnected at this time. This will protect the PNA from damage.
2. Connect the PNA jumpers for Ports 1 and 2 SOURCE OUT and RCVR IN connectors.
3. Connect the Z5623AH83 to the PNA, see [Figure 35, "Setup Configuration."](#) Depending on your application set up, not all pulse pattern generators may be required as shown in this figure.

Figure 35 Setup Configuration

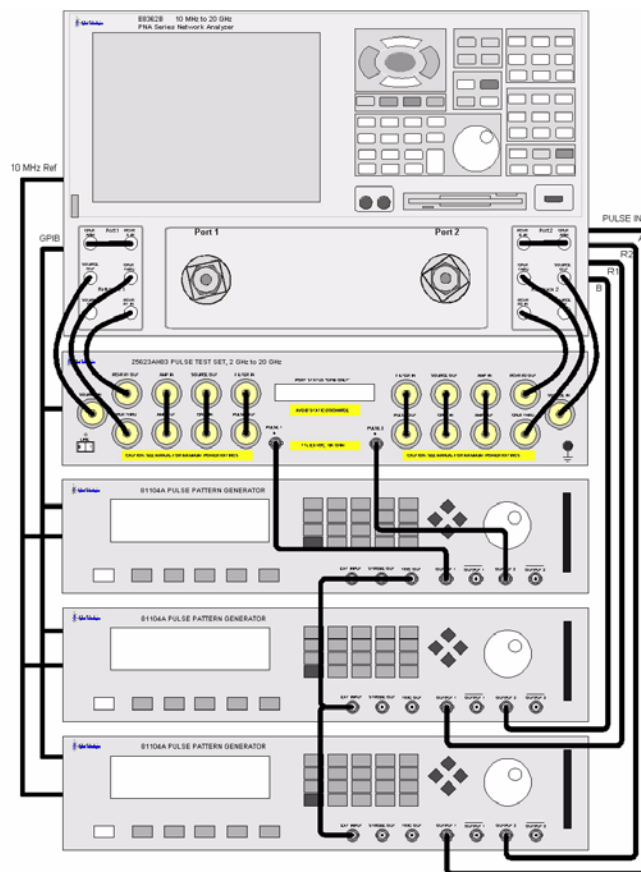

4. If the Z5623AH83 is in the Shipped mode configuration (all the jumpers are still on) remove the jumper between AMP OUT and AMP IN connector on the front panel for Port 1. This can also be done for Port 2 if high power measurements are necessary for the reverse parameters of a device under test (DUT). Two booster amplifiers are required for both forward and reverse measurements, see [Figure 36](#).
5. Place four terminations on J1-J4 on the rear panel for AMP 1 and 2.
6. Verify that the Booster Amplifier is turn off at this time.
7. Connect the Booster Amplifier RF INPUT connector to the Port 1 AMP OUT connector on the front panel of the Z5623AH83.
8. Remove the jumper on the Z5623AH83 between SOURCE OUT and CPLR IN. Place an isolator or attenuator between the SOURCE OUT and CPLR IN on the port 2 side.

Figure 36 Connect Booster Amplifier

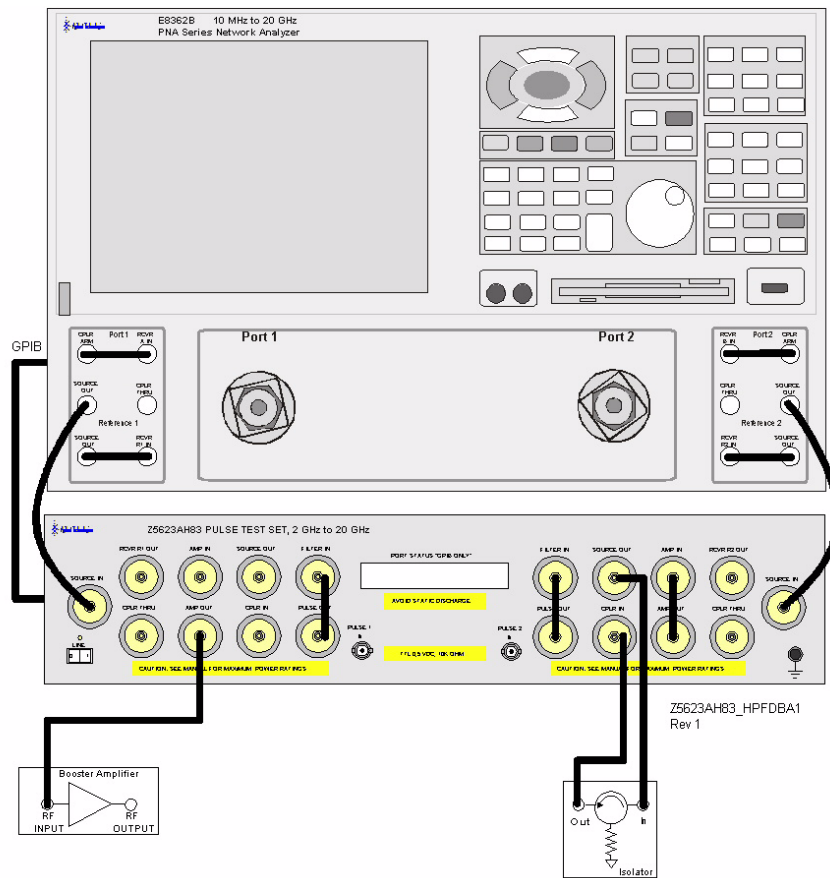

Determining Power Levels

Before continuing, save this state and set it up as the **User Preset** key. The User Preset Conditions can be found in the PNA Series Network Analyzer's help menu.

9. Press **[Menu/Dialog]** then tab to **Help**. Select **Network Analyzer Help**. Type in *User Preset*, this will describe how to setup a User Preset. The final state should be saved as the User Preset to avoid an over power condition from the factory preset.

To find the User Preset:

10. Press **[Menu/Dialog]** then tab to **System**. Scroll down to **User Preset**. Click on **User Preset Enable** and press **Save**, then **OK**. This will save the current state as **User Preset**.
11. Turn on the analyzer and decrease the power level to -20 dBm by pressing **[Menu/Dialog]** then tab to **Channel**. In the pull down menu select **Power**. Scroll to **Port Selection** enter **[-20]**. Select **Port Power Coupled** to ensure that Ports 1 and 2 power levels are the same. Uncoupled ports should be used when adjusting the S12 power level or when Port 1 has a very low power level in comparison to Port 2.

NOTE Frequency Offset mode (Option 080) and External R1 (Option 081) must be activated when using the analyzer in a high power configuration. This will ensure phase lock and allow the R1 and R2 to receive the new reference power levels from the amplifiers.

- Press **[Menu/Dialog]** then tab to **Channel**. In the pull down menu select **Frequency Offset** and turn on the **Frequency Offset Mode**. In the Offset Setting set the **Offset** to **[0]**.
- Press **[Menu/Dialog]** then tab to **Channel**. In the pull down menu select **Test Set**. Select the **External R1 Loop** in the R1 Input Path window.

12. Set the Z5623AH83 Test Set so that the external booster amplifier is in the RF path. Refer to [“Controlling the Test Set” on page 27](#) to set the external Booster Amplifier to be engaged in the RF path.
13. Turn on the booster amplifier.
14. Measure the output power from the booster amplifier RF Output using a power meter and sensor.

NOTE Additional attenuation may have to be added between the coupler and the power meter, depending on the power used.

15. Verify the gain of the Booster Amplifier(s). For example; if the analyzer's output power level was set to -20 dBm and the output power measured from the open end of the coupler was -5 dBm, the gain of the booster amplifier would be $+15$ dB.
16. Verify that the power measured in the previous steps is within the acceptable limits (less than $+43$ dBm for the AMP IN port).
17. Turn off the booster amplifier.
18. Estimate the maximum power level that will be needed to force the DUT into compression. Acceptable limits are less than $+43$ dBm for the AMP IN port.

CAUTION Do not command the test set to engage *or* disengage the amplifier from the Port 1 RF path while the amplifier is on. This can damage the internal RF switches in the test set.

19. Verify that the Booster Amplifier is turned off.
20. Connect the Booster Amplifier RF OUTPUT connector to the Port 1 AMP IN connector on the front panel of the Z5623AH83.
21. Turn on the Booster Amplifier.
22. Using a high power meter and sensor, measure the output power from the test sets RCVR R1 port.
23. Turn off the Booster Amplifier.
24. Estimate the maximum power level that will be needed to force the DUT into compression.

Selecting Power Ranges and Attenuator Settings

25. Select a power range that will not exceed the maximum estimated power level, but will force the DUT into compression. For example; if your Booster Amplifier has a gain of +15 dB and the DUT will compress if supplied with +15 dBm, then you would adjust the analyzer's output power not to exceed 0 dBm. This can be done by setting Attenuator Control to 10 dB by pressing **Power**, under **Attenuator Control**, uncheck **Auto** and enter **[10]** into the entry area. In the "Port Selection" area the Port Power Coupled can be checked to ensure that Port 1 and 2 power levels are the same, or unchecked if Port 1 and 2 power level requirements are different.
26. Estimate the maximum amount of gain that could be provided by the DUT and as a result, the maximum amount of power that could be received by Test Port 2 when the DUT is in compression. For example; if a DUT with a maximum gain of +10 dB receives an input of +10 dBm, then the maximum amount of power that could be received by Test Port 2 is +20 dBm. An isolator or attenuator may be required depending on the amount of power at Test Port 2. An isolator is placed between the CPLR IN and SOURCE OUT to protect the test set and the PNA.
27. Calculate the amount of attenuation needed between the analyzer's coupler and receivers so that you do not exceed the optimum receiver power level of -15 dBm. Refer to your PNA specifications to optimize power levels to the receiver ports.

It will be necessary to take the following into consideration:

- Power measured at the test sets RCVR R1 OUT = -2 dBm
 - Estimated compression power = -2 dBm.
 - The optimum PNA receiver power level is -15 dBm
28. Set the internal Z5623AH83 Test Set RCVR R1 step attenuator to the value calculated below (rounding off to the highest 10 dB step). Refer to ["Controlling the Test Set" on page 27](#) to set the Attenuator for RCVR R1 OUT path.

With the previous points in mind, the amount of attenuation can be calculated from the following equations:

$$\text{Attenuator RCVR R1 Setting} = -2 \text{ dBm} - (-15 \text{ dBm}) = 13 \text{ dBm}$$

$$\text{RCVR R1 Attenuator Value} = 20$$

29. Turn on the Booster Amplifier.
30. Measure the output power from the test sets RCVR R1 using a high power meter and sensor.
31. Verify that the power measured in the previous step is within the acceptable limits (-15 dBm at the RCVR R1 OUT).

32. Measure the output power from the test sets CPLR THRU port using a high power meter and sensor.
33. Turn off the Booster Amplifier.
34. Verify that the power measured in the previous step is within the acceptable limits (less than +43 dBm at the CPLR THRU port).
35. Calculate the amount of attenuation needed between the analyzer's coupler and receivers so that you do not exceed the optimum receiver power level of -15 dBm.

It will be necessary to take the following into consideration:

- Receiver A will be coupled to the analyzer RF path that could receive power reflections as high as +10 dBm.
 - Receiver B will be coupled to the analyzer RF path that could receive a maximum of +20 dBm from the DUT.
 - Analyzer coupler loss is -13 dB.
 - The optimum receiver power level is -15 dBm.
36. Set the internal step attenuator to the value calculated below (rounding off to the highest 5 dB step). Setting the receiver attenuation will set the internal attenuation. Press **[Menu/Dialog]** then tab to **Channel**. In the pull down menu select **Power**, under Receiver Attenuation set Receiver A to **[10]** and Receiver B to **[20]**. Power levels greater than +35 dBm will require additional attenuation between Port 2, access ports CPLR ARM and RCVR B IN.

With the previous points in mind, the amount of attenuation can be calculated from the following equations:

$$\text{Receiver Attenuator A} = 10 \text{ dBm} - 13 \text{ dBm} - (-15 \text{ dBm}) \quad \text{Attenuator A} = 12 \text{ dBm}$$

$$\text{Receiver Attenuator B} = 20 \text{ dBm} - 13 \text{ dBm} - (-15 \text{ dBm}) \quad \text{Attenuator B} = 22 \text{ dBm}$$

Additional Setup

37. Remove the PNA SOURCE OUT and the RCVR IN jumpers.
38. Insert the jumpers between the PNA and the test set RCVR RI, RCVR R2, and CPLR THRU ports.
39. Turn on the Booster Amplifier.
40. Measure the output power from test Port 1 using a high power sensor. Verify that the power level is as expected.

Figure 37 Connect PNA and Test Set Jumpers

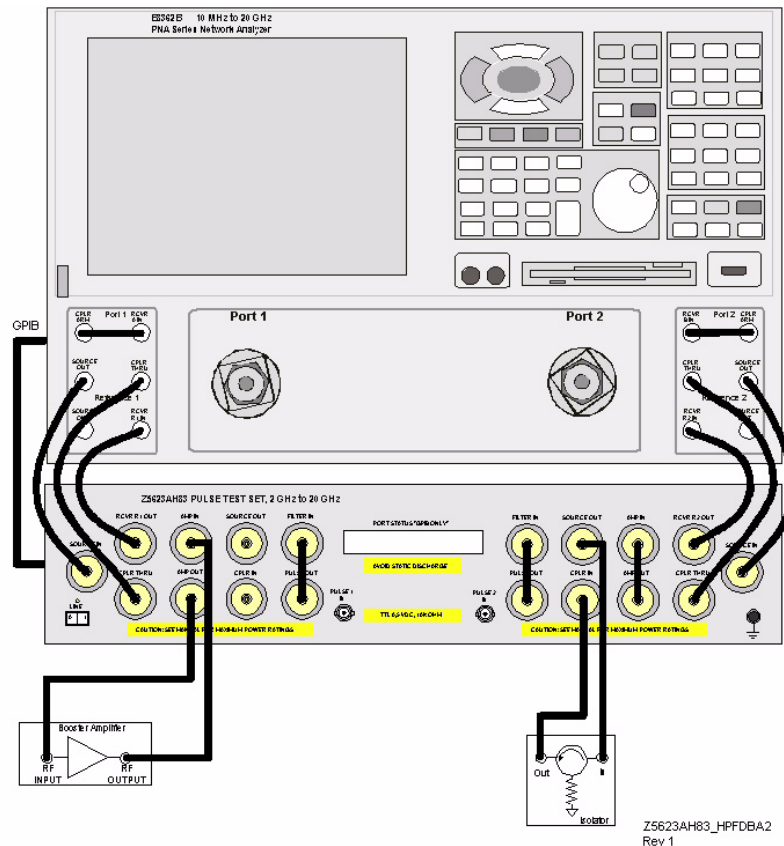

Z5623AH83_HPFDBA2
Rev 1

CAUTION Do not press Preset unless you have turned off the Booster Amplifier(s) or have saved this state and renamed it to User Preset. Pressing Preset will return the analyzer to its default power level and default internal attenuator settings. The increase in power may result in damage to the DUT or analyzer.

CAUTION High power isolators should be inserted between the SOURCE OUT and CPLR IN front panel ports on the test set if you are measuring a highly reflective device. The increase in power may result in damage to the analyzer

Final Setup and Response Calibration

41. Verify that all of the power and attenuator settings are correct, and set the following measurement. Press **[Menu/Dialog]** then tab to **Trace**. In the pull down menu select **Measure** then **S21**.
42. Connect the analyzers test port cables to form a thru configuration.
43. Press **[Menu/Dialog]** then tab to **Calibration**. In the pull down menu select **Calibration Wizard** and then **Unguided Calibration Use Mechanical Standards**. Select **THRU Response**. Follow the analyzers window prompts to finish the calibration.
44. Make the connection as shown in [Figure 38](#).

Figure 38 Connecting the DUT

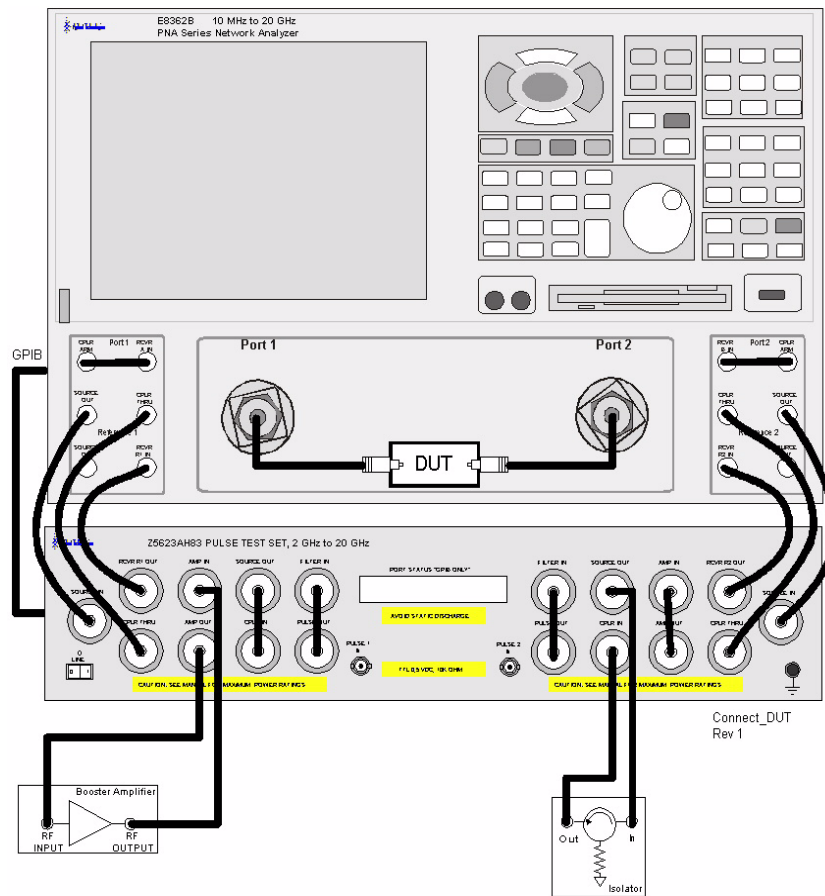

45. Turn on the DUT and measure the S21 gain of the amplifier under test to confirm the proper operation of the measurement test setup.
46. Continue with any other high power measurements.

NOTE Ratio measurements, such as gain, will be correctly displayed. However, the displayed absolute power levels on the analyzer will *not* be correct. To correctly interpret power levels and the gain of the booster amplifier, the attenuator setting must be taken into consideration.

If no calibration has been performed or if the instrument is in an un-calibrated state, the following must be taken into consideration when interpreting the measured data:

- The value of attenuation added to receiver A and B.
- The R channel reference level supplied from the test set.
- Protection of the internal parts for the test set and PNA.

This procedure can be repeated to setup the reverse high power configuration.

Test Set Internal Configurations

The Z5623AH83 can be internally configured to allow the user to configure it for different application requirements. In this section we will show the test sets internal configurations. The Test Sets Port 1 side is a mirror image of the Port 2 side. Both sides are independent of each other.

For simplicity the Port 1 side will be used for the following examples.

There are four basic mode configurations.

- Bypass
- High Power
- Pulse
- Pulse High Power
- Amplifier Terminate

Bypass

The bypass mode sets the Test Set's internal switches so that the SOURCE IN port thru path connects directly to the CPLR THRU port. This allows you to use the PNA in a normal operation. The test port and R1 reference power at the PNA will be reduced due to the loss of the test set. [Figure 39](#) shows the main signal flow through the test set Port 1 side, which is identical to the Port 2 side.

Figure 39 Bypass

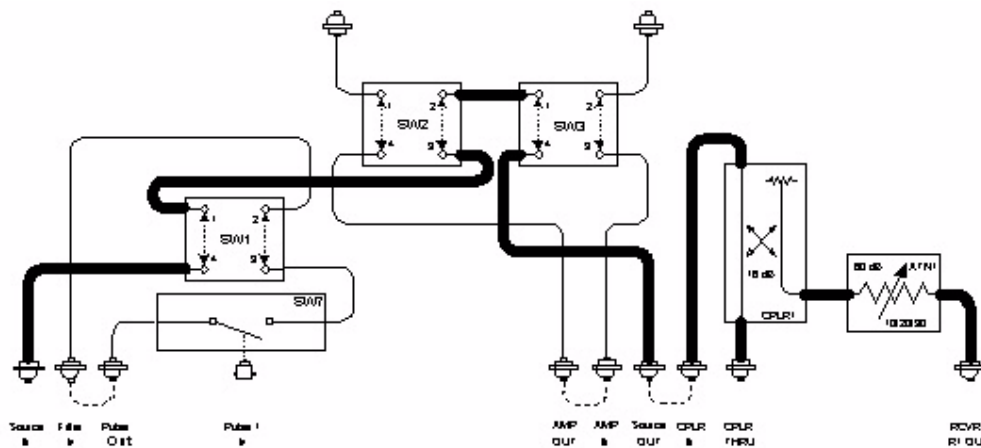

High Power

The high power mode sets the Test Set's internal switches so that the SOURCE IN port thru path connects to the AMP OUT and AMP IN ports, and then to the CPLR THRU port. This allows the user to insert a Booster Amplifier in the RF path. Figure 40 shows the main signal flow through the test set Port 1 side, which is identical to the Port 2 side.

Figure 40 High Power

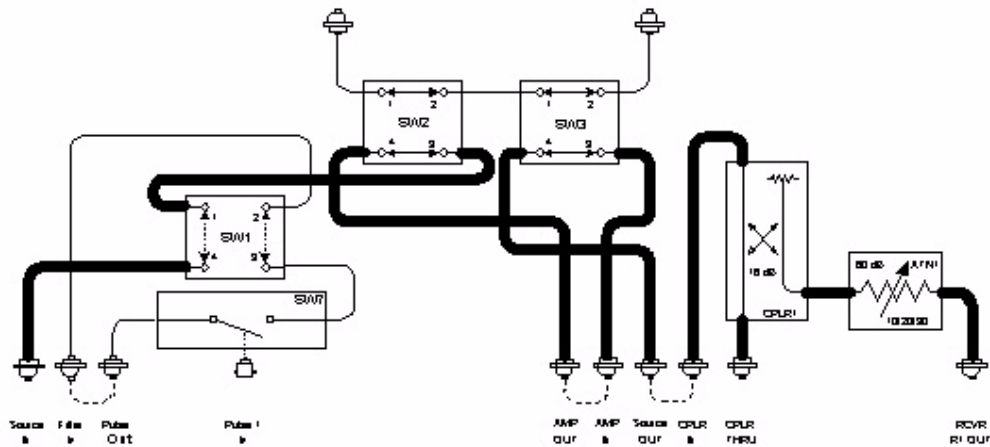

Pulse

The pulse mode sets the Test Set's internal switches so that the SOURCE IN port thru path connects to the PIN switch modulator, directly to the CPLR THRU port. This allows the user to make lower power pulse measurement. Figure 41 shows the main signal flow through the test set Port 1 side, which is identical to the Port 2 side.

Figure 41 Pulse

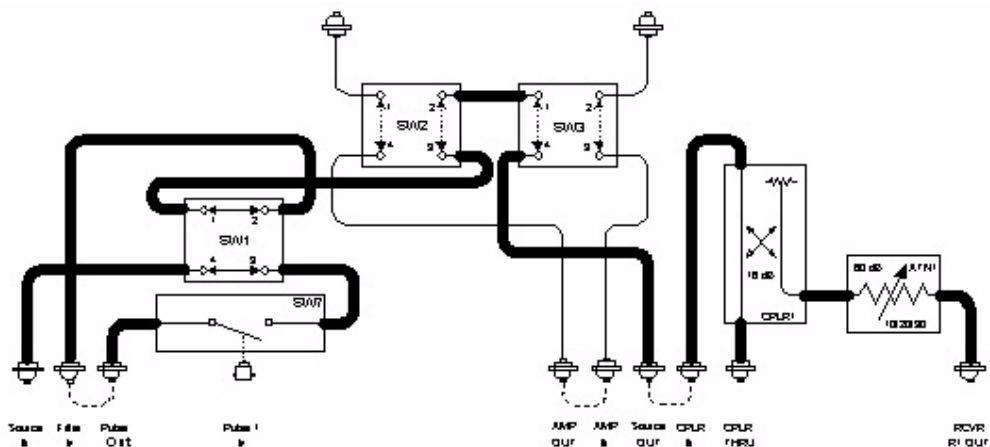

Pulse High Power

The pulse high power mode sets the Test Set’s internal switches so that the SOURCE IN port thru path connects to the PIN switch modulator, then to the AMP OUT and AMP IN ports, and then to the CPLR THRU port. This allows user to insert a booster amplifier in the pulsed RF path. [Figure 42](#) shows the main signal flow through the test set Port 1 side, which is identical to the Port 2 side.

Figure 42 Pulse High Power

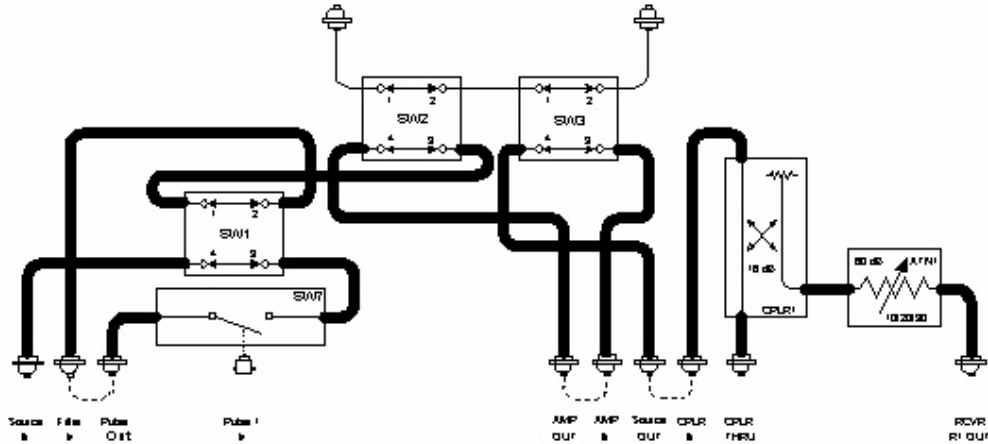

Amplifier Terminate

The terminate amplifier is set in the bypass and pulse mode. This sets the Test Set’s internal switches so that the AMP IN and AMP OUT RF ports are routed to the rear panel Amp Term 1 ports. Customer furnished terminations can be connected to these ports so that you may customize your power requirements. This allows the user to terminate the Booster Amplifiers input and output. [Figure 43](#) shows the main signal flow through the test set Port 1 side, which is identical to the Port 2 side.

Figure 43 Amplifier Termination

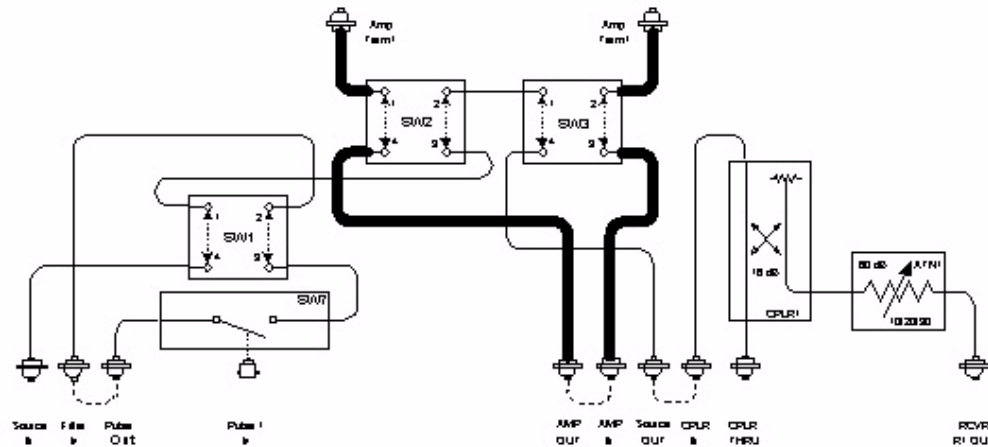

Specification

Specifications for the Z5623AH83 Dual Directional Pulse Test Set are nominal.

Pulsed RF PIN Switch Modulator

Transition Time: 30 nanoseconds (typically < 20 nanoseconds)

Rise/Fall Time (10% to 90%): 20 nanoseconds (typically < 10 nanoseconds)

Pulse Width (minimum): 100 nanoseconds

Trigger Level (External): 10 k Ω TTL, “0” ON, “1” OFF, TTL-low-level signal turns RF on.

Maximum Power Input: 20 dBm

On/Off Ratio: 70 dB (typically > 80 dB, 400 MHz to 2 GHz)

Frequency Range: 2 to 20 GHz

E8362B Option H11

Widest Bandwidth: 10 kHz

Trigger Level (External): TTL

Trigger Width (minimum): 20 nanoseconds

Table 6 Nominal System Performance

Item	Unit of Measure		
	Nominal system Performance (Not tested at this time)	0.01 to 2 GHz	2 to 20 GHz
Maximum Power at Port 1 ¹ (nominal)	-10 dBm	-20 dBm	
Reference Power at Port 1 ² (nominal)	-25 dBm	-35 dBm	
Minimum Power at Port 1 ³ (nominal)	-80 dBm	-80 dBm	
System Dynamic Range ⁴ (bypass mode)	110 dBm	100 dBm	
System Dynamic Range ⁴ (pulse mode)	Pulse ⁵	NA	70 dB
	Non- Pulse ⁵	NA	80 dB

1. This maximum power measurement assumes that the PNA source attenuator is set to 0 dB and the power level is set to a -5 dBm (default power level on for the E8363B and E8364B).
2. RCVR R1 & R2 OUT measured from 1 to 20 GHz due to internal coupler roll off below 1 GHz. The roll off adds -3 dB at 500 MHz, -15 dB at 100 MHz, and -20 dB at 50 MHz from the measured response value at 1 GHz.
3. This minimum power measurement is in bypass mode.
4. Forward transmission measurements. Limited by compression level and noise floor.
5. System Dynamic Range “Pulse” indicates the ON/OFF ratio of the PIN switch. The Non Pulse indicates when the PIN switch is on and not used in a pulse mode application.

Test Set Performance Verification

Equipment Required

- E8362B Network Analyzer 10 MHz to 20 GHz or equivalent
- 85052D Calibration kit or equivalent
- 81110A with 81111A Pulse Pattern Generator
- (2) 3.5 mm RF cables (36 in or equivalent)
- 86100A Infinium DCA Wideband Oscilloscope
- 86112A Two Channel 20 GHz Module

Procedure

To test the performance of the Z5623AH83 this document assumes that the user is familiar with the necessary equipment. The PNA USB keyboard and mouse will necessary to enter GPIB commands and to read the trace data. Measurements can be made easier by setting up Markers with search, tracking, and search domain user states for each of the frequency bands.

Using the PNA as the controller to issue commands to the Z5623AH83 Test Set can be found in [“Controlling the Test Set” on page 27](#).

General S-Parameters are used to characterize the connection paths of the test set. Both reflection and transmission measurements are required. These measurements are made with the E8362B, 3.5 mm calibration kit and RF cables. Power Output and Pulse Shape are not measured to re-verify the Z5623AH83 test set.

A Full 2-Port SLOT (short, load, open, thru) Calibration should be performed on the PNA at the ends of the RF cables. The Isolation must not be omitted. The calibration should be performed at the following settings.

Start Freq	10 MHz
Stop Freq	20 GHz
IF bandwidth	100 Hz
Power level	-5 dBm
Number of points	401

CPLR Thru S-Parameters

1. Connect the RF cables as shown in [Figure 44, “CPLR Thru S-Parameters,”](#) which shows the configuration for Port 1 and Port 2 setup. This measures the Source In to CPLR THRU S-Parameters and On/Off Ratio for the Port 1 and Port 2. Connect the Port 1 side first, then repeat the procedure for Port 2. Record the data in [Table 7 on page 65.](#)
2. Set the Z5623AH83 Test Set to the Bypass mode using the PNA as the controller. Measure the S-Parameters for the Source In to CPLR THRU. Record the performance data in [Table 7.](#)
3. Connect a 50 Ω load to the RCVR Out Port.
4. Verify that the Pulse In is set to 0 Volts on the 81111A and set the impedance on the Output to 1000 Ω
5. Set the Z5623AH83 Test Set to the High Power mode using the PNA as the controller. Measure the S-Parameter for the Source In to CPLR THRU. Record the data in [Table 7.](#)
6. Set the Z5623AH83 Test Set to the High Power Pulse mode using the PNA as the controller. Measure the S-Parameter for the Source In to CPLR THRU. Record the data in [Table 7](#) for frequencies between 2 to 20 GHz only.
7. Set the Z5623AH83 Test Set to the Pulse mode using the PNA as the controller. Measure the S-Parameter for the Source In to CPLR THRU. Record the data in [Table 7](#) for frequencies between 2 to 20 GHz only.
8. Repeat this procedure for the Port 2 side.

Figure 44 CPLR Thru S-Parameters

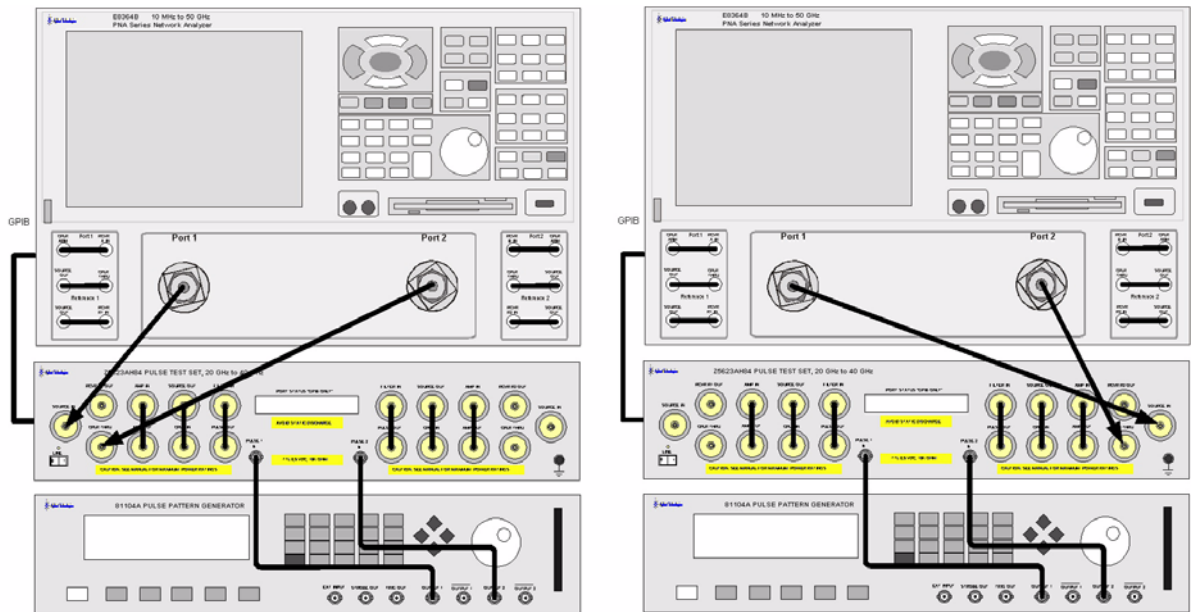

Z5623AH84_on_off
Rev_1

RCVR Port S-Parameters

1. Connect the RF cables as shown in [Figure 45](#) which shows the configuration for Port 1 and Port 2 setup. This measures the Source In to REF 1 OUT and REF 2 OUT S-Parameters for the Port 1 and Port 2. Connect the Port 1 side first, then repeat the procedure for Port 2. Record the data in [Table 8](#) on [page 65](#).
2. Set the Z5623AH83 Test Set to the Bypass mode using the PNA as the controller. Measure the S-Parameters for the Source In to REF OUT. Record the data in [Table 8](#) for frequencies between 2 to 20 GHz only.
3. Connect a 50 Ω load to the CPLR Thru Port.
4. Verify that the Pulse In is set to 0 Volts on the 81111A and set the impedance on the Output to 1000 Ω .
5. Repeat this procedure for the Port 2 side.

Figure 45 RCVR Port S-Parameters

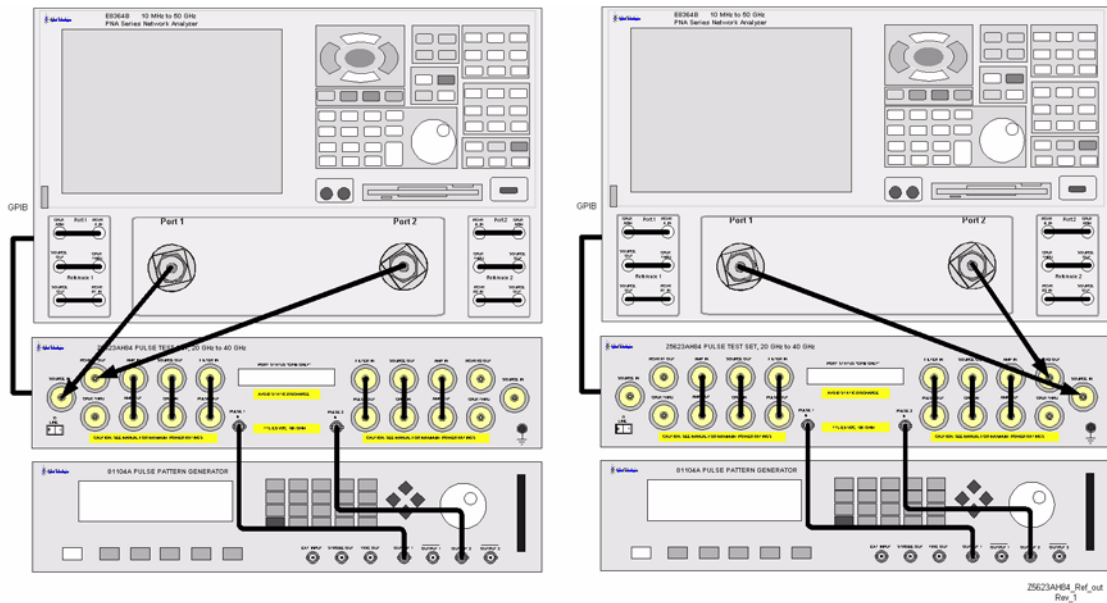

On/Off Switch Ratio

1. Connect the RF cables as shown in [Figure 46](#) which shows the configuration for Port 1 and Port 2 setup. This measures the Source In to REF 1 OUT and REF 2 OUT S-Parameters and Reference Attenuators for Port 1 and Port 2. Connect the Port 1 side first, then repeat the procedure for Port 2. Record the data in [Table 9](#) on [page 66](#).
2. Verify that the Pulse In is set to 0 Volts on the 81111A and set the impedance on the Output to 1000 Ω .
3. Set the Z5623AH83 Test Set to the Pulse mode using the PNA as the controller. Measure the S-Parameter for the Source In to Pulse Out. Record the data in [Table 9](#).
4. Set the PNA to measure S21 only. Normalize the S21 response.
5. Set the Pulse In to 5 Volts by changing the 81111A Output to 5 Volts.
6. Measure the On/Off Ratio. Record the data in [Table 9](#).
7. Repeat this procedure for the Port 2 side.

Figure 46 On/Off Switch Ratio

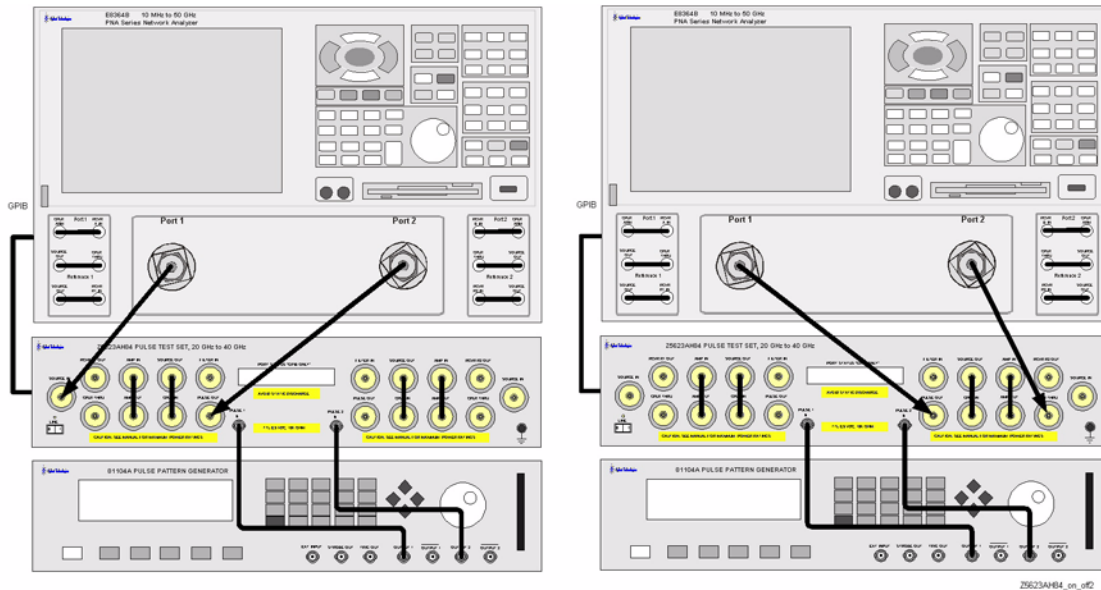

Attenuator Settings

1. Connect the RF cables as shown in [Figure 47](#). This configuration measures the CPLR IN to REF 1 OUT Reference Attenuators for Port 1 and Port 2. Connect the Port 1 side first, then repeat the procedure for Port 2. Record the data in [Table 9 on page 66](#).
2. Connect a 50 Ω load to the CPLR Thru Port.
3. Set the PNA to measure S21 only. Normalize the S21 response.
4. Set Marker 1 to 2 GHz. The attenuator setting is measured at 2 GHz only to test the attenuators relative attenuation for each setting. The noise floor of the PNA limits measurements when the test sets attenuator setting is greater than 40 dB. Frequencies above 6 GHz at low power levels make measurements difficult. Frequencies below 1 GHz are also difficult due to the coupler roll off.
5. Set the Z5623AH83 Test Set Reference Attenuator in 10 dB steps 10-60 dB and measure the response. Record the data in [Table 9](#).
6. Repeat this procedure for the Port 2 side.

Figure 47 Attenuator Steps

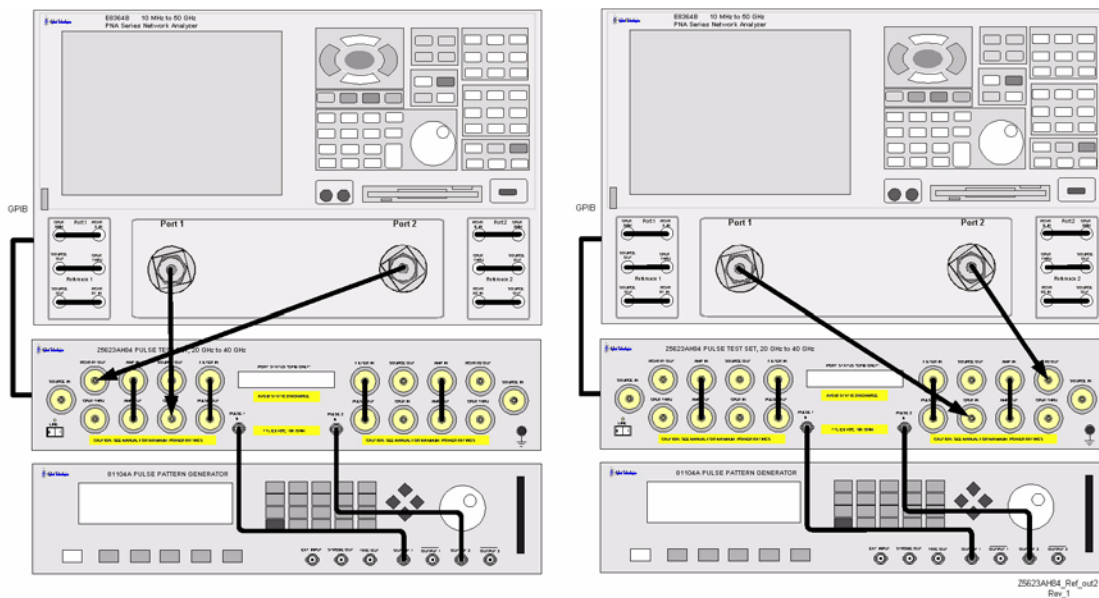

Rear Panel Termination Test

1. Connect the 50 Ω loads to the rear panel connectors J1, J2, J3, and J4.
2. Set the PNA to measure S11 and S22.
3. Set the Z5623AH83 Test Set to the Bypass mode using the PNA as the controller. Measure the S-Parameter to the Amp In and Amp Out for J4 and J3. Record the data in [Table 9 on page 66](#).
4. Repeat this procedure for the Port 2 side and record the data for J2 and J1.

Figure 48 Rear Panel Termination

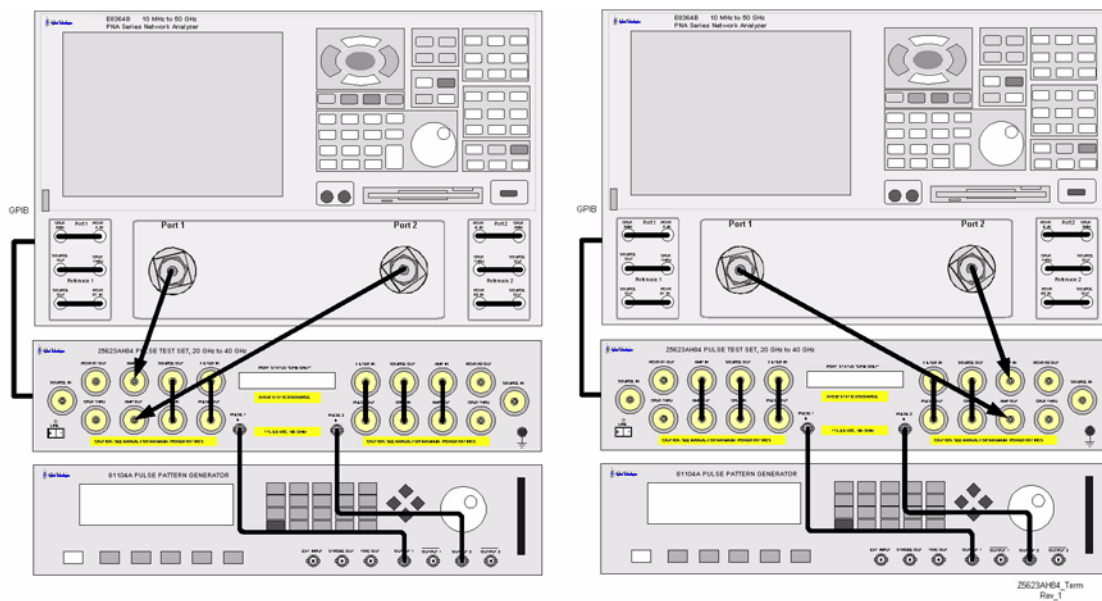

Rise and Fall Time Test

1. Connect the RF cables shown in [Figure 51 on page 64](#). This configuration measures the rise and fall times of the PIN switch modulators in the test set. Connect the Port 1 side first, then repeat the procedure for Port 2. Record the data in [Table 9 on page 66](#).
2. Set the E8362B to **[CW mode] [Frequency] [20 GHz]**.
3. Set the E8362B **[Power Level] [-20 dBm]**.
4. Turn the 81110A Output 1 **On**.
5. Set the 81110A **[LEVEL] Normal > High 5 Volts > Low 0 Volts > 50 to 1 kΩ**
6. Set the 81110A **[TRIGGER MODE] to Continuous > Pulse Signal to Output 1 > Pulse Period to Internal Osc.**
7. Set the 81110A **[TIMING] to Freq 100 kHz > Delay 0 ns > Duty Cycle 90% > LeadEdg 2 ns > TrailingE = LeadE.**
8. Set the 81110A **[PATTERN] to Update Continuous > CH1 to 1.**
9. Set the 86100A for **Channel 1 On > Scale to 10 mv > Time to 2 μs**. Position the pulse to the right edge of display.
10. Expand the **Time** scale to measure the pulse amplitude at 100 ns. You may need to reposition the pulse to keep the rising edge on the display.
11. Measure the amplitude of the Positive pulse side by setting the **solid horizontal marker** to the center of the trace 0 Volts. Set the **dash horizontal marker** to the maximum Positive Pulse amplitude. Measure the delta voltage. The following equation will allow you to calculate the 10% and 90% rise and fall time.

$$10\% \text{ point} = \text{delta (positive pulse)} \times 0.1$$

$$90\% \text{ point} = \text{delta (positive pulse)} \times 0.9$$

Figure 49 Delta Voltage

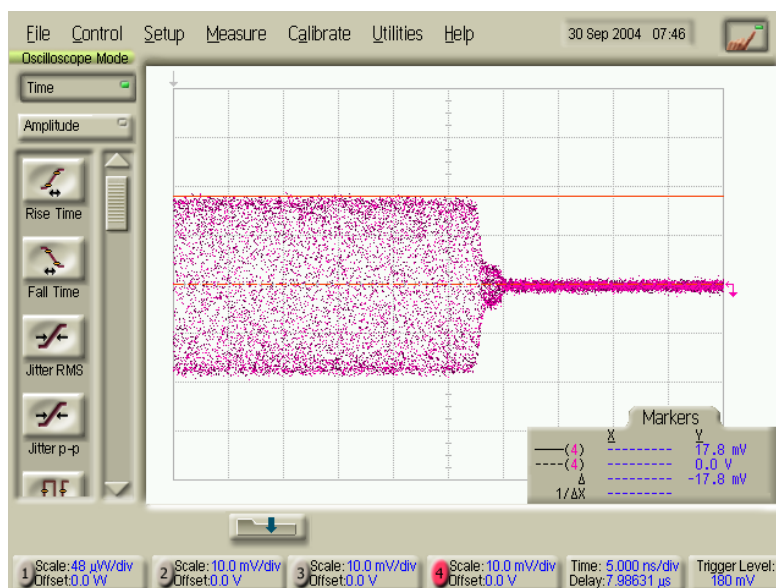

12. Set the **solid horizontal marker** to the 10% point and the **dash horizontal marker** to the 90% point.
13. Expand the **Time scale** of the oscilloscope for **5 ns**, keeping the pulses rise time in view.
14. Set the **vertical solid marker** to the 10% point and the **vertical dash marker** to 90%, and measure the rise time by reading the delta vertical Marker. Record the rise time in [Table 9 on page 66](#).
15. Increase the Time scale to 100 ns. Position the Marker on the pulses fall time to the right on the display and then expand the scale to 5 ns keeping the pulse fall time in view.
16. Set the **vertical solid marker** to the 90% point and the **vertical dash marker** to 10%, measure the fall time by reading the delta vertical marker. Record the fall time in [Table 9](#).

Figure 50 Fall Time

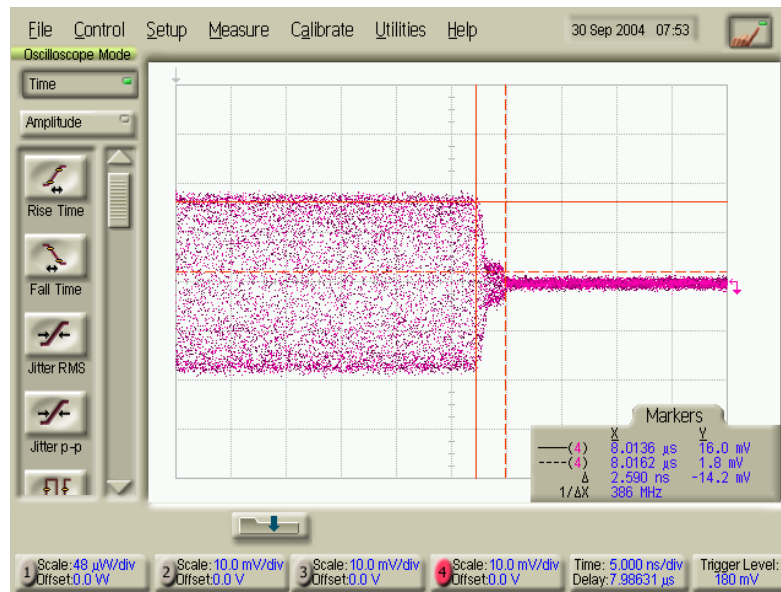

17. Repeat [Step 9](#) through [Step 16](#) for 10 GHz and 20 GHz by changing the CW frequency on the E8362B and measure the rise and fall times.

Figure 51 Rise and Fall Time Setup

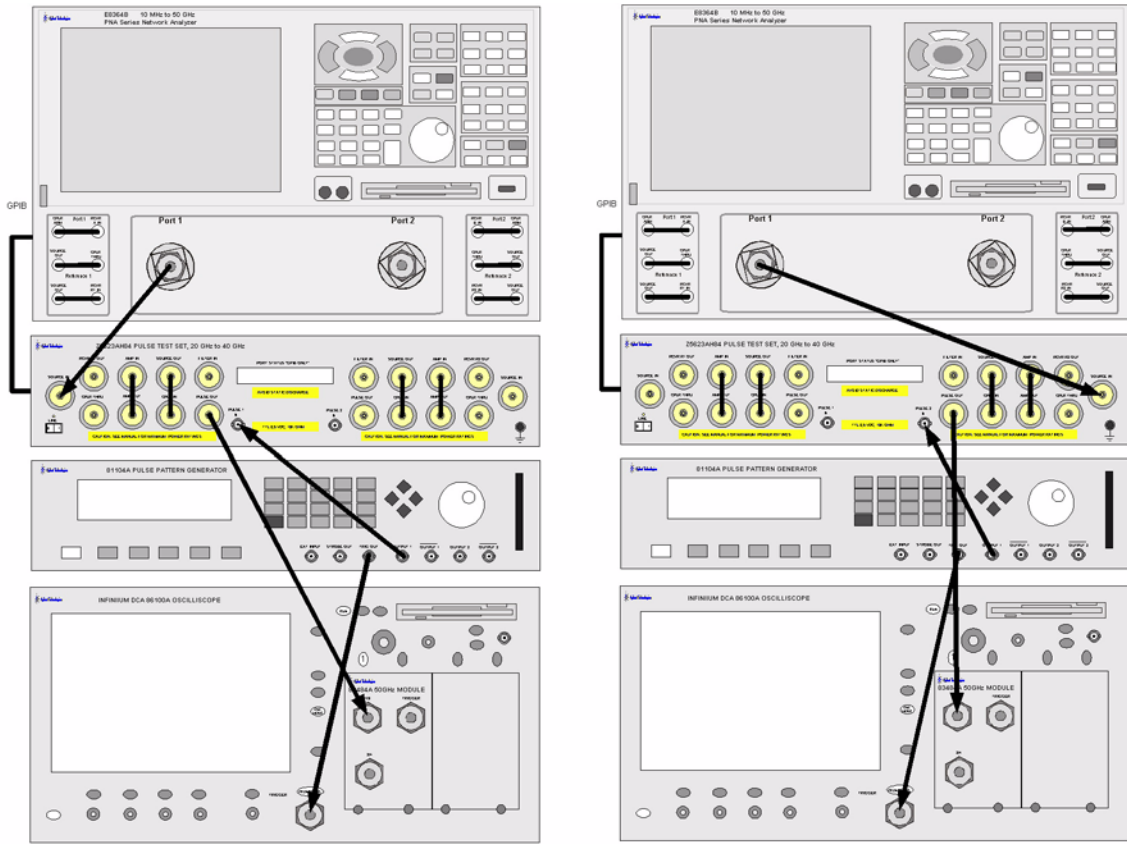

Z5623AH84_Rise_Fall
Rev_1

Table 7 Performance Data (Port 1 & 2 to CPLR THRU)

Port/Connection/Mode	0.01 to 2 GHz		2 to 20 GHz	
	Spec (dB)	Meas	Spec (dB)	Meas
Port 1 SOURCE IN to CPLR THRU¹				
Bypass				
S11, S22	18		8	
S21, S12	-5		-11	
High Power				
S11, S22	18		8	
S21, S12	-6		-13	
Pulse				
S11, S22	n/a	n/a	6	
S21, S12	n/a	n/a	-17	
Port 2 SOURCE IN to CPLR THRU¹				
Bypass				
S11, S22	18		8	
S21, S12	-5		-11	
High Power				
S11, S22	18		8	
S21, S12	-6		-13	
Pulse				
S11, S22	n/a	n/a	6	
S21, S12	n/a	n/a	-17	

1. Pulse path measurement specifications start at 2 GHz.

Table 8 Performance Data (Port 1 & 2 to RCVR R1 & R2 OUT)

Port/Connection/Mode	1 to 2 GHz		2 to 20 GHz	
	Spec (dB)	Meas	Spec (dB)	Meas
Port 1 SOURCE IN to RCVR R1 OUT¹				
Bypass				
S11, S22	18		8	
S21, S12	-21		-27	
Port 2 SOURCE IN to RCVR R2 OUT¹				
Bypass				
S11, S22	18		8	
S21, S12	-21		-27	

1. RCVR R1 & R2 OUT measured from 1 to 20 GHz due to internal coupler roll off below 1 GHz. The roll off adds -3 dB at 500 MHz, -15 dB at 100 MHz, and -20 dB at 50 MHz from the measured response value at 1 GHz.

Table 9 Performance Data (On/Off, Attenuation, Rise and Fall)

Port/Connection/Mode	0.01 to 2 GHz		2 to 20 GHz					
On/Off Switch Ratio Normalized S21 Response	Spec (dB)	Meas	Spec (dB)	Meas				
Port 1 side ¹	n/a	n/a	70					
Port 2 side ¹	n/a	n/a	70					
Attenuator Setting ² Normalized S21 Response	Specification ± 3.5 dB				Measured Value			
Port 1 Side								
10	10							
20	20							
30	30							
40	40							
50	50							
60	60							
Port 2 Side								
10	10							
20	20							
30	30							
40	40							
50	50							
60	60							
Rear Panel Match	J4 (AMP IN)		J3 (AMP OUT)		J2 (AMP IN)		J1 (AMP OUT)	
	Spec (S22 dB)	Meas	Spec (S11 dB)	Meas	Spec (S22 dB)	Meas	Spec (S11 dB)	Meas
AMP IN/OUT Term Ports	8		8		8		8	
Rise and Fall Time	Rise Time Spec (ns)		Meas		Fall Time Spec (ns)		Meas	
Port 1 Side								
2 GHz	20				20			
10 GHz	20				20			
20 GHz	20				20			
Port 2 Side								
2 GHz	20				20			
10 GHz	20				20			
20 GHz	20				20			

1. Typically > 80 dB, 400 MHz to 2 GHz.

2. Marker 1 data measured at 2 GHz only with 0 dB attenuation in the RCVR Out path normalized.
This is a functional check only.

Replaceable Parts

Table 10 **Replaceable Parts List**

Ref Designator	Description	Agilent Part Number
	PWR-SPLY; power-110W; number of Outputs=4	0950-2252
ATTN1-ATTN2	Attenuator assembly (60 dB 3-Section)	33325-60006
FP/RP RF Conn	Connector assembly (bulkhead)	5062-6618
CPLR1-CPLR2	Coupler (50 GHz)	5086-7658
	Daughter controller board	87050-60324
	Board assembly interim	87050-63149
SW1-SW6	26.5 GHz transfer switch	87222-60001
SW7-SW8	μ -Wave PIN diode switch (2 to 20 GHz)	Z5623-80030
	Pulse bias board assy	Z5623-63293
	Manual control interface assembly	Z5623-63364
	User's and Service Guide (Option H83)	Z5623-90070

Safety and Regulatory Information

Introduction

Review this product and related documentation to familiarize yourself with safety markings and instructions before you operate the instrument. The documentation contains information and warnings that must be followed by the user to ensure safe operation and to maintain the product in a safe condition.

Connector Care and Cleaning

If alcohol is used to clean the connectors, the power cord to the instrument must be removed. All cleaning should take place in a well ventilated area. Allow adequate time for the fumes to disperse and moist alcohol to evaporate prior to energizing the instrument.

WARNING

To prevent electrical shock, disconnect the Agilent Technologies model product from mains before cleaning. Use a dry cloth or one slightly dampened with water to clean the external case parts. Do not attempt to clean internally.

Before Applying Power

Verify that the product is configured to match the available main power source. If this product is to be powered by autotransformer, make sure the common terminal is connected to the neutral (grounded) side of the ac power supply.

Shipping Instructions

You must always call the Agilent Technologies Instrument Support Center to initiate service before retuning your instrument to a service office. Refer to [“Contacting Agilent Sales and Service Offices” on page 75](#). Always transport or ship the instrument using the original packaging if possible. If not, comparable packaging must be used. Attach a complete description of the failure symptoms.

Declaration of Conformity

For a copy of the manufacturer’s Declaration of Conformity for this apparatus, refer to [“Contacting Agilent Sales and Service Offices” on page 75](#).

Statement of Compliance

This product has been designed and tested in accordance with IEC Publication 1010, Safety Requirements for Electronic Measuring Apparatus, and has been supplied in a safe condition. The instruction documentation contains information and warnings which must be followed by the user to ensure safe operation and to maintain the instrument in a safe condition.

Compliance with Canadian EMC Requirements

This ISM device complies with Canadian ICES-001. Cet appareil ISM est conforme a la norme NMB du Canada.

Compliance with German Noise Requirements

This is to declare that this instrument is in conformance with the German Regulation on Noise Declaration for Machines (Laermangabe nach der Maschinenlaermverordnung-3, GSGV Deutschland).

Acoustic Noise Emission/Geraeuschemission	
LpA<70 dB	Lpa<70 dB
Operator Position	am Arbeitsplatz
Normal Operation	normaler Betrieb
per ISO 7779	nach DIN 45635 t. 19

Warnings

WARNING The **WARNING** notice denotes a hazard. It calls attention to a procedure which if not correctly performed or adhered to, could result in personal injury. Do not proceed beyond a **WARNING** notice until the indicated conditions are fully understood and met.

Warnings applicable to this instrument are:

WARNING To prevent electrical shock, disconnect the **Agilent Technologies Z5623A Option H83** from mains before cleaning. Use a dry cloth or one slightly dampened with water to clean the external case parts. Do not attempt to clean internally.

WARNING For continued protection against fire hazard replace line fuse only with same type and rating:

- F 3.0A/250V, Part Number 2110-0780

The use of other fuses or material is prohibited.

WARNING This is a Safety Class I product (provided with a protective earthing ground incorporated in the power cord). The mains plug shall be inserted only into a socket outlet provided with a protective earth contact. Any interruption of the protective conductor, inside or outside the product is likely to make the product dangerous. Intentional interruption is prohibited.

WARNING These servicing instructions are for use by qualified personnel only. To avoid electrical shock, do not perform any servicing unless you are qualified to do so.

WARNING The opening of covers or removal of parts is likely to expose dangerous voltages. Disconnect the instrument from all voltage sources while it is being opened.

WARNING This product is designed for use in Installation Category II and Pollution Degree 2 per IEC 61010-1: 2001.

WARNING No operator serviceable parts inside. Refer servicing to qualified personnel. To prevent electrical shock do not remove covers.

WARNING **If this product is not used as specified, the protection provided by the equipment could be impaired. This product must be used in a normal condition (in which all means for protection are intact) only.**

Cautions

CAUTION The CAUTION notice denotes a hazard. It calls attention to an procedure that, if not correctly performed or adhered to, could result in damage to or destruction of the product. Do not proceed beyond a CAUTION notice until the indicated conditions are fully understood and met

Cautions applicable to this instrument are:

CAUTION Always use the three-prong ac power cord supplied with this instrument. Failure to ensure adequate earth grounding (by not using this cord) can cause instrument damage.

CAUTION This product is designed for use in Installation Category II and Pollution Degree 2 per IEC 61010-1:2001.

CAUTION This instrument has autoranging line voltage input; be sure the supply voltage is within the specified range.

CAUTION Ventilation Requirements: When installing the instrument in a cabinet, the convection into and out of the instrument must not be restricted. The ambient temperature (outside the cabinet) must be less than the maximum operating temperature of the instrument by 4 °C for every 100 watts dissipated in the cabinet. If the total power dissipated in the cabinet is greater than 800 watts, forced convection must be used.

Instrument Markings



The instruction documentation symbol. The product is marked with this symbol when it is necessary for the user to refer to the instructions in the documentation.



This symbol indicates that the instrument requires alternating current (ac) input.



This symbol indicates separate collection for electrical and electronic equipment, mandated under EU law as of August 13, 2005. All electric and electronic equipment are required to be separated from normal waste for disposal (Reference WEEE Directive, 2002/96/EC).



This symbol indicates that the power line switch is ON.



This symbol indicates that the power line switch is in the STANDBY position.



This symbol indicates that the power line switch is in the OFF position.



This symbol is used to identify a terminal which is internally connected to the product frame or chassis.



The CE mark is a registered trademark of the European Community. (If accompanied by a year, it is when the design was proven.)



The CSA mark is a registered trademark of the Canadian Standards Association. This instrument complies with Canada: CSA 22.2 No. 000000061010-1, Second Edition.



This is a symbol of an Industrial Scientific and Medical Group 1 Class A product.



This is a marking to indicate product compliance with the Canadian Interference-Causing Equipment Standard (ICES-001).



Direct Current.



This is a required mark signifying compliance with an EMC requirement. The C-Tick mark is a registered trademark of the Australian Spectrum Management Agency.



China RoHS regulations include requirements related to packaging, and require compliance to China standard GB18455-2001.



This symbol indicates compliance with the China RoHS regulations for paper/fiberboard packaging.

Contacting Agilent Sales and Service Offices

Assistance with test and measurement needs, and information on finding a local Agilent office are available on the Internet at:

<http://www.agilent.com/find/assist>

You can also purchase accessories or documentation items on the Internet at:

<http://www.agilent.com/find>

If you do not have access to the Internet, contact your field engineer.

NOTE

In any correspondence or telephone conversation, refer to the product by its model number and full serial number. With this information, the Agilent representative can determine whether your unit is still within its warranty period.
